

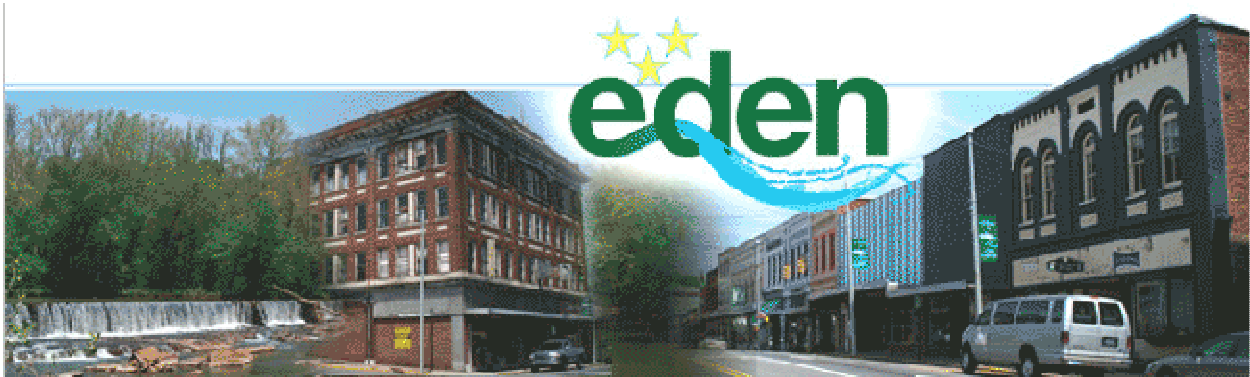

North Carolina Department of Transportation
Transportation Planning Branch

Comprehensive Transportation Plan



City of Eden

April 2009

Comprehensive Transportation Plan Study Report

City of Eden

Prepared by the: Transportation Planning Branch
Division of Highways
N.C. Department of Transportation

In Cooperation with: The City of Eden
Piedmont Triad Rural Planning Organization
The Federal Highway Administration
U.S. Department of Transportation

April 2009



Wayne C. Davis, Ph.D., P.E.

Wayne C. Davis, Ph.D., P.E.
Triad Planning Group Supervisor

Acknowledgments

Persons responsible for this report:

Project Engineer:	John A. Bailey
Planning Group Supervisor:	Wayne C. Davis, PhD, P.E.
Western Unit Head:	Earlene Thomas, P.E.
Manager, Transportation Planning Branch:	Mike Bruff, P.E.

Special thanks to those who greatly contributed to the report:

Kelly Stultz, AICP – City of Eden Planning Director

Hanna Cockburn, AICP – Piedmont Triad Council of Governments

Executive Summary

In August of 2005, the Transportation Planning Branch of the North Carolina Department of Transportation and the City of Eden agreed to cooperatively develop the City of Eden Comprehensive Transportation Plan. The ensuing transportation plan was a product of this effort.

This report documents the findings of this study, the current and future transportation needs, as well as the resulting recommendations for improvements. In addition, this report presents cross-section recommendations, cost estimates for the recommended improvements, and environmental features found in the study area.

The recommendations for major improvements are summarized below. A more detailed description of these and other recommendations can be found in Chapter 2.

- NC 14-87

It is recommended that NC 14-87 be improved to boulevard standards from the Virginia State Line to the southern planning area boundary. This includes:

- TIP Project R-4402; upgrading the existing two and three lane section from the Virginia State Line to NC 700-770/SR 3003 (Meadow Road) to a four-lane facility with partial control of access measures implemented.
- The addition of a median along the current five-lane section from NC 700-770/SR 3003 (Meadow Road) to the southern planning area boundary to facilitate partial control of access.
- The construction of urban interchanges at the intersections of SR 2066 (Kings Highway) and NC 87-770.

These improvements will increase capacity, improve safety, and relieve congestion.

- NC 14-87 (Bypass)

It is recommended that a bypass be constructed to route through traffic around the primary business area of the City of Eden. This bypass should be constructed from SR 1605 (N. Oakland Ave), onto existing SR 1557 (Westerly Park Rd), and on a new location to NC 770. This bypass should be signed from SR 1605 to the intersection of NC 14 and NC 87-770. This bypass should be a two-lane facility with 12-foot lanes. These improvements will increase capacity, improve safety, and relieve congestion on existing NC 14-87 as well as route through traffic around the city's primary business area.

- SR 2066 (W. Kings Highway)
It is recommended that SR 2066 (W. Kings Highway) be improved to from SR 1605 (S. Bridge Street) to NC 14-87-770. The addition of a median along this current five-lane section should be constructed to facilitate partial control of access. These improvements will increase capacity, improve safety, and relieve congestion.
- SR 3003 (W. Meadow Road)
It is recommended that SR 3003 (W. Meadow Road) be improved from SR 3002 (Boone Road) to SR 1747 (W. Stadium Drive). The current two-lane facility from SR 3002 to SR 1747 should be widened to four-lanes with partial control of access measures implemented. These improvements will increase capacity, improve safety, and relieve congestion.
- Harrington Highway Eastern Extension
It is recommended that Harrington Highway be extended from its current terminus at the intersection of NC 14 and NC 87-770 east onto existing SR 1951 (Quesinberry Road) to NC 700. This should be a two-lane facility with 12-foot lanes. These improvements will relieve congestion on existing NC 14-87 by routing industrial traffic to the eastern side of the city.
- West Draper Spur
It is recommended a new route be constructed from NC 770 to the proposed Harrington Highway Eastern Extension. This should be a two-lane facility with 12 foot-lanes. These improvements will relieve congestion on existing NC 14-87 by routing industrial traffic to the eastern side of the city.

After coordination with city officials and the Piedmont Triad Rural Planning Organization (PTRPO), as well as several informational meetings with the City Council Members and the citizens of Eden, the City of Eden Comprehensive Transportation Plan was formally adopted on November 18, 2008. The Piedmont Triad Rural Planning Organization endorsed this plan on December 17, 2008. The North Carolina Board of Transportation (NCBOT) officially adopted this plan on February 5, 2009.

Prioritization and implementation of this plan lies primarily with the city and its citizens. The City of Eden should work with the PTRPO to prioritize their transportation needs. This organization is responsible for presenting the needs to the North Carolina Department of Transportation. The needs of the state far exceed the amount of available funding; therefore it is crucial that the City of Eden aggressively pursue any and all available funding for desired projects.

Adopted by:

City of Eden
Date: November 18, 2008

NCDOT
Date: February 5, 2009

Endorsed by:

Piedmont Triad RPO
Date: December 17, 2008

Recommended by:

Transportation Planning Branch
Date: December 29, 2008

NOTES:

Format for Sheet 5 Pedestrian map is pending.

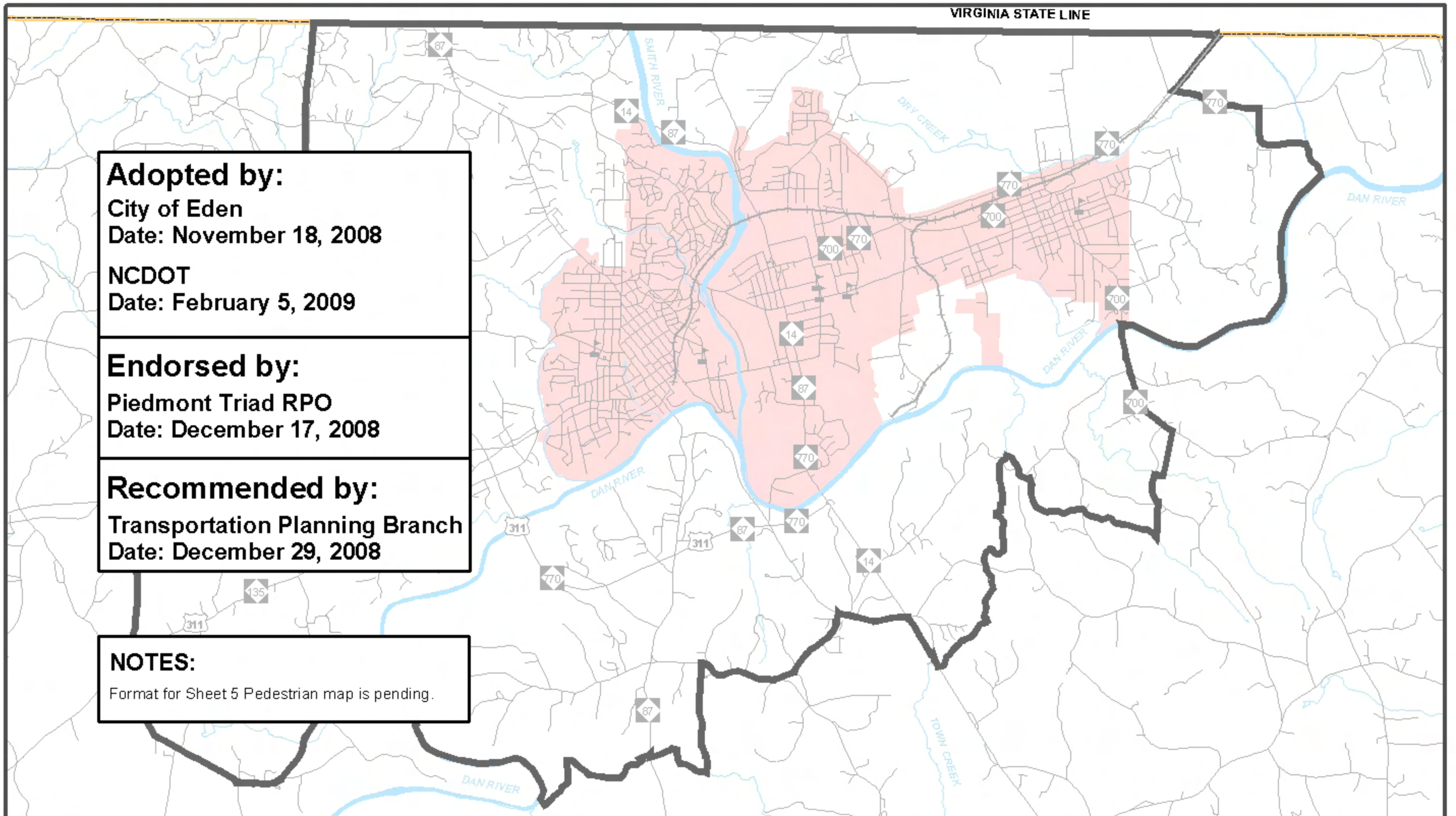

- Sheet 1 Adoption Sheet
- Sheet 2 Highway Map
- Sheet 3 Public Transportation and Rail Map
- Sheet 4 Bicycle Map
- Sheet 5 Pedestrian Map

Legend

- Schools
- Roads
- Lakes
- Rivers and Streams
- Railroads
- Planning Boundary
- County Boundary
- City Limits

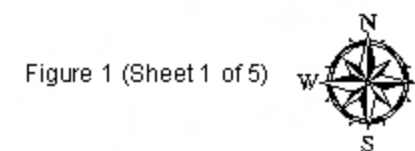

Figure 1 (Sheet 1 of 5)

Base map date: September 2007

Refer to CTP document for more details

City of Eden
 Rockingham County
 North Carolina
**Comprehensive
 Transportation Plan**

Plan date: November 18, 2008

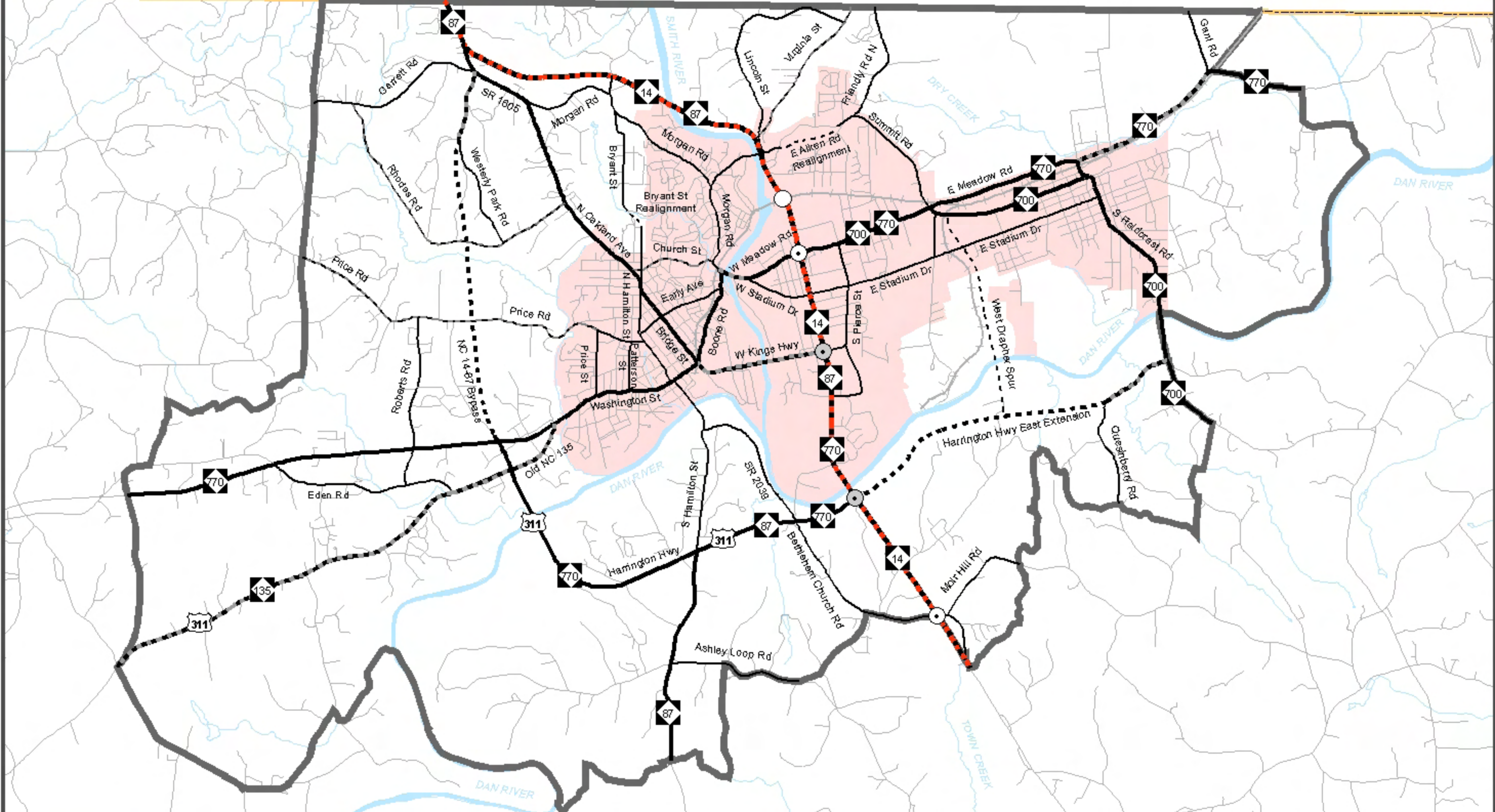

Freeways

- Existing
- Needs Improvement
- Recommended

Expressways

- Existing
- Needs Improvement
- Recommended

Boulevards

- Existing
- Needs Improvement
- Recommended

Other Major Thoroughfares

- Existing
- Needs Improvement
- Recommended

Minor Thoroughfares

- Existing
- Needs Improvement
- Recommended

Interchanges

- Existing Interchange
- Proposed Interchange
- Existing Grade Separation
- Proposed Grade Separation

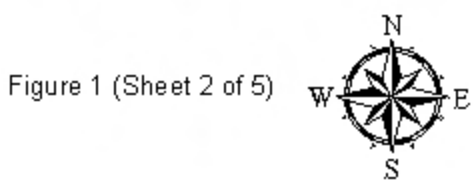
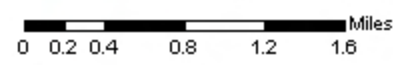

Figure 1 (Sheet 2 of 5)

Base map date: September 2007

Refer to CTP document for more details

Highway Map

City of Eden

Comprehensive Transportation Plan

Plan date: November 18, 2008

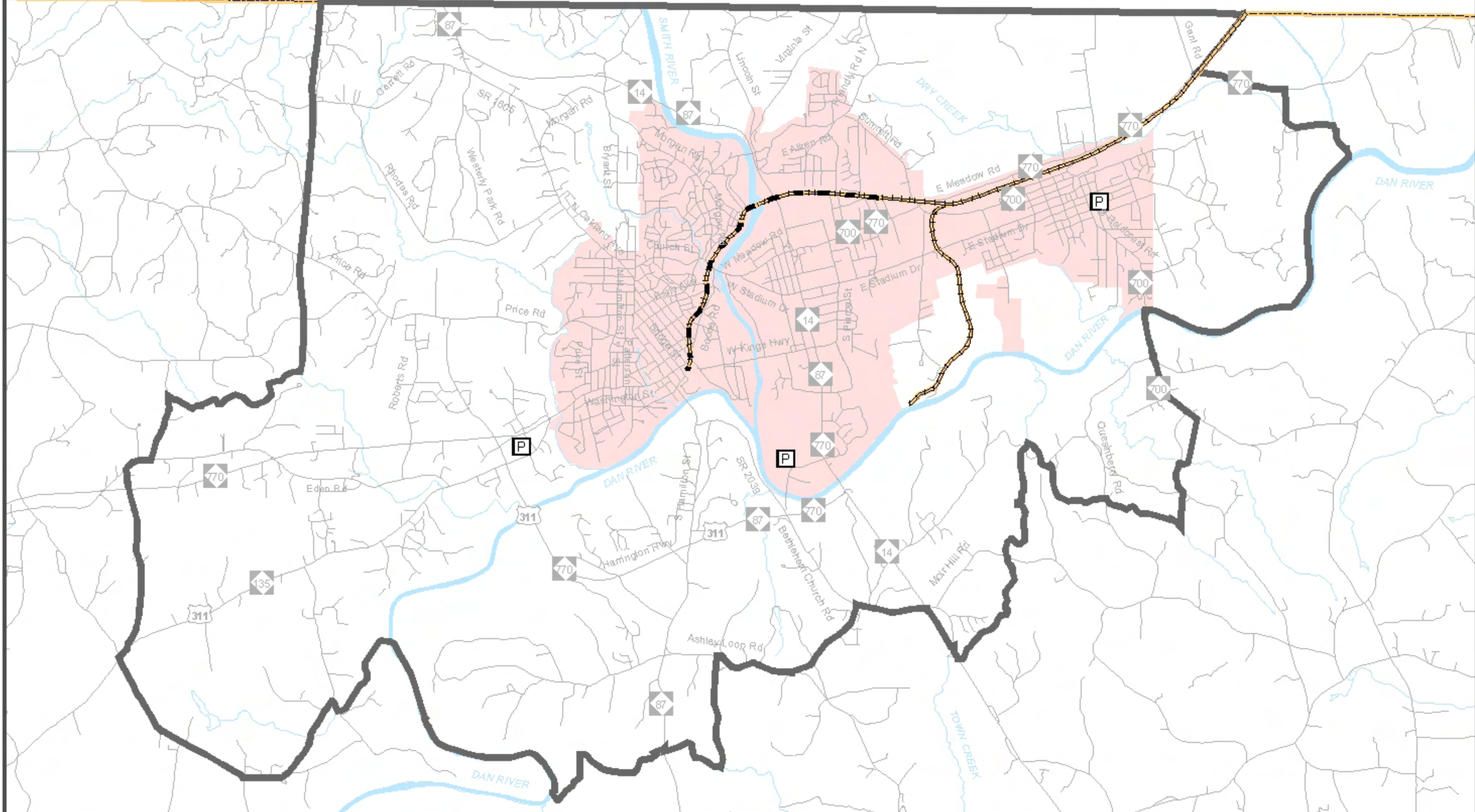

Bus Routes

- Existing
- Needs Improvement
- Recommended

Fixed Guideway

- Existing
- Needs Improvement
- Recommended

Operational Strategies

- Existing
- Needs Improvement
- Recommended

Rail Corridor

- Active
- Inactive
- Recommended

High Speed Rail Corridor

- Existing
- Recommended

Rail Stops

- Existing
- Recommended

Intermodal Connector

- Existing
- Recommended

Park and Ride Lot

- Existing
- Recommended



Figure 1 (Sheet 3 of 5)

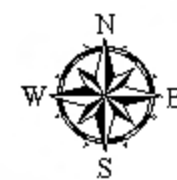

Base map date: September 2007

Refer to CTP document for more details

Public Transportation and Rail Map

**City of Eden
Comprehensive
Transportation Plan**

Plan date: November 18, 2008

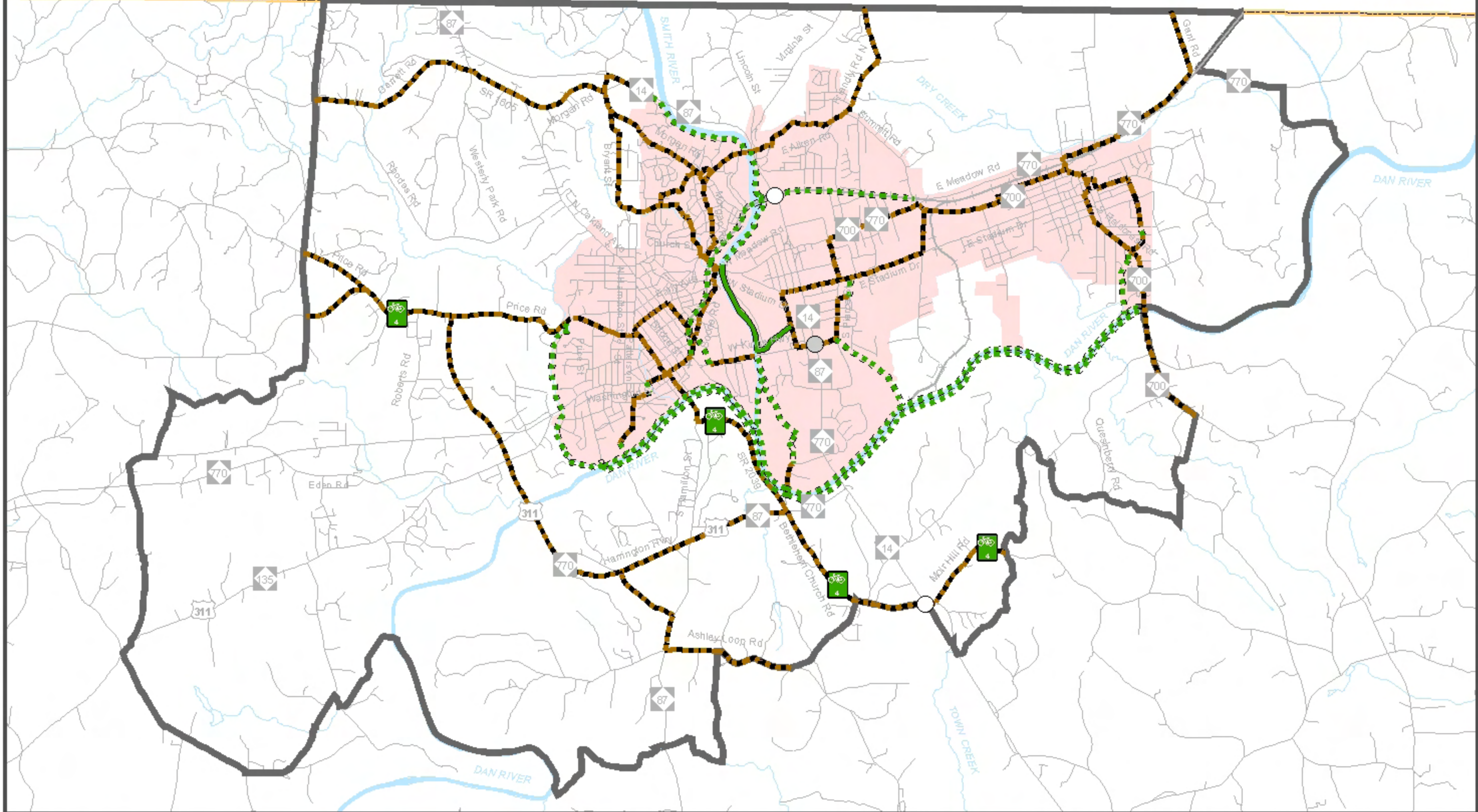

On Road

- Existing
- Needs Improvement
- Recommended

- Existing Grade Separation
- Proposed Grade Separation

Off Road

- Existing
- Needs Improvement
- Recommended

Multi-Use Paths

- Existing
- Needs Improvement
- Recommended

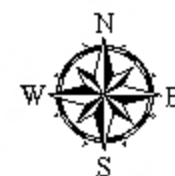

Figure 1 (Sheet 4 of 5)

Base map date: September 2007

Refer to CTP document for more details

Bicycle Map

City of Eden
Comprehensive
Transportation Plan

Plan date: November 18, 2008

Table of Contents

I. Introduction	1
II. Recommendations	5
Highway Map	5
Major Improvements	6
Minor Widening Improvements	13
Other Improvements	13
Public Transportation and Rail Map	14
Bicycle Map	15
Pedestrian Map	16
III. Implementation	17
State-County Adoption of the Transportation Plan	17
Methods Used to Protect the Adopted Transportation Plan	17
Funding Sources	19
Implementation Recommendations	20
IV. Population, Land Use, and Roadway Conditions	21
Population	21
Land Use	22
Roadway System	29
Traffic Crash Analysis	29
Bridge Conditions	35
Roadway Capacity Deficiencies	39
Level of Service	45
V. Environmental Screening	47
Wetlands	47
Threatened and Endangered Species	47
Historic Sites	48
Educational Facilities	49
VI. Public Involvement	55

Appendices

Appendix A	Resources and Contacts	A-1
Appendix B	Comprehensive Transportation Plan Definitions	B-1
Appendix C	Street Tabulation and Recommendations	C-1
Appendix D	Typical Cross-Sections	D-1
Appendix E	Recommended Subdivision Ordinances	E-1
Appendix F	Population and Employment Projections	F-1
Appendix G	Public Involvement	G-1
Appendix H	Previous Thoroughfare Plan Map	H-1
Appendix I	Transportation Improvement Program Project Process	I-1
Appendix J	Travel Demand Modeling Process	J-1

List of Figures

Figure 1	Comprehensive Transportation Plan	iii
Figure 2	Geographic Location	3
Figure 3	City of Eden Existing Land Use	23
Figure 4	City of Eden Future Land Use	25
Figure 5	City of Eden Growth Strategy	27
Figure 6	Crash Locations	33
Figure 7	Structurally Deficient and Functionally Obsolete Bridges	37
Figure 8	2007 Highway Deficiencies	41
Figure 9	2035 Highway Deficiencies	43
Figure 10	Level of Service Illustrations	46
Figure 11	Environmental Features I	51
Figure 12	Environmental Features II	53

List of Tables

Table 1	Funding Sources and Recommended Methods of Implementation	20
Table 2	Population Growth	21
Table 3	Severity Index	30
Table 4	Severity Index at High Crash Locations	31
Table 5	Bridge Deficiencies	35
Table 6	2007 Capacity Deficiencies	40
Table 7	2035 Capacity Deficiencies	40
Table 8	Threatened or Endangered Species	48

I. Introduction

An area's transportation system is its lifeline, contributing to its economic prosperity as well as its social being. The importance of a transportation system infrastructure that is safe and efficient cannot be overstressed. This system should provide a means of transporting people and goods from one place to another quickly, conveniently, and above all, safely. A system that is well planned will not only meet existing demands, but also keep pace with the growth of the region.

The City of Eden, acknowledging the importance of transportation planning for future transportation needs, requested transportation planning assistance from the North Carolina Department of Transportation (NCDOT) – Transportation Planning Branch (TPB) to complete a Comprehensive Transportation Plan (CTP).

This report documents the development of the 2008 City of Eden CTP presented in Figure 1, Sheets 1-4. In addition, this report documents recommendations for each mode of transportation. This plan replaces the 1997 Eden Thoroughfare Plan shown in Appendix H.

The City of Eden is located in the north-central part of Rockingham County in northern North Carolina. The geographical location for the City of Eden is presented in Figure 2.

A comprehensive transportation plan is developed to ensure that the transportation system will progressively meet the needs of an area. The CTP will serve as an official guide to providing a well-coordinated, efficient, and economical transportation system utilizing all modes of transportation. This document will be used by local officials to ensure that planned transportation facilities reflect the needs of the public, while minimizing disruption to local residents, businesses, and the environment.

The purpose of a CTP is to examine present and future transportation needs of the community. The plan recommends improvements that are necessary to provide a safe, convenient, and efficient transportation system within the 2007-2035 planning period.

Initiative for the implementation of the CTP rests primarily with the policy board and citizens of the community. The City of Eden and the North Carolina Department of Transportation share the responsibility for any proposed construction.

The CTP is based on the projected growth of the City of Eden as forecasted through the cooperative effort between the NCDOT and city leaders. It may be possible that actual growth patterns will differ from those logically anticipated in this plan. Therefore, it may be necessary to accelerate or delay the development of some of the recommendations in this plan. Some portions of this plan may require revisions in order to accommodate unexpected changes in urban development.

Figure 2: Geographic Location

CITY OF EDEN Rockingham County North Carolina

PREPARED BY THE
NORTH CAROLINA DEPARTMENT OF TRANSPORTATION
TRANSPORTATION PLANNING BRANCH
IN COOPERATION WITH THE
U.S. DEPARTMENT OF TRANSPORTATION
FEDERAL HIGHWAY ADMINISTRATION

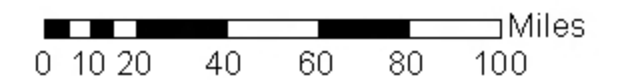
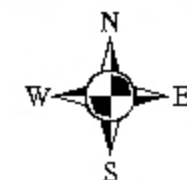

BASE MAP DATE: SEPTEMBER 2007

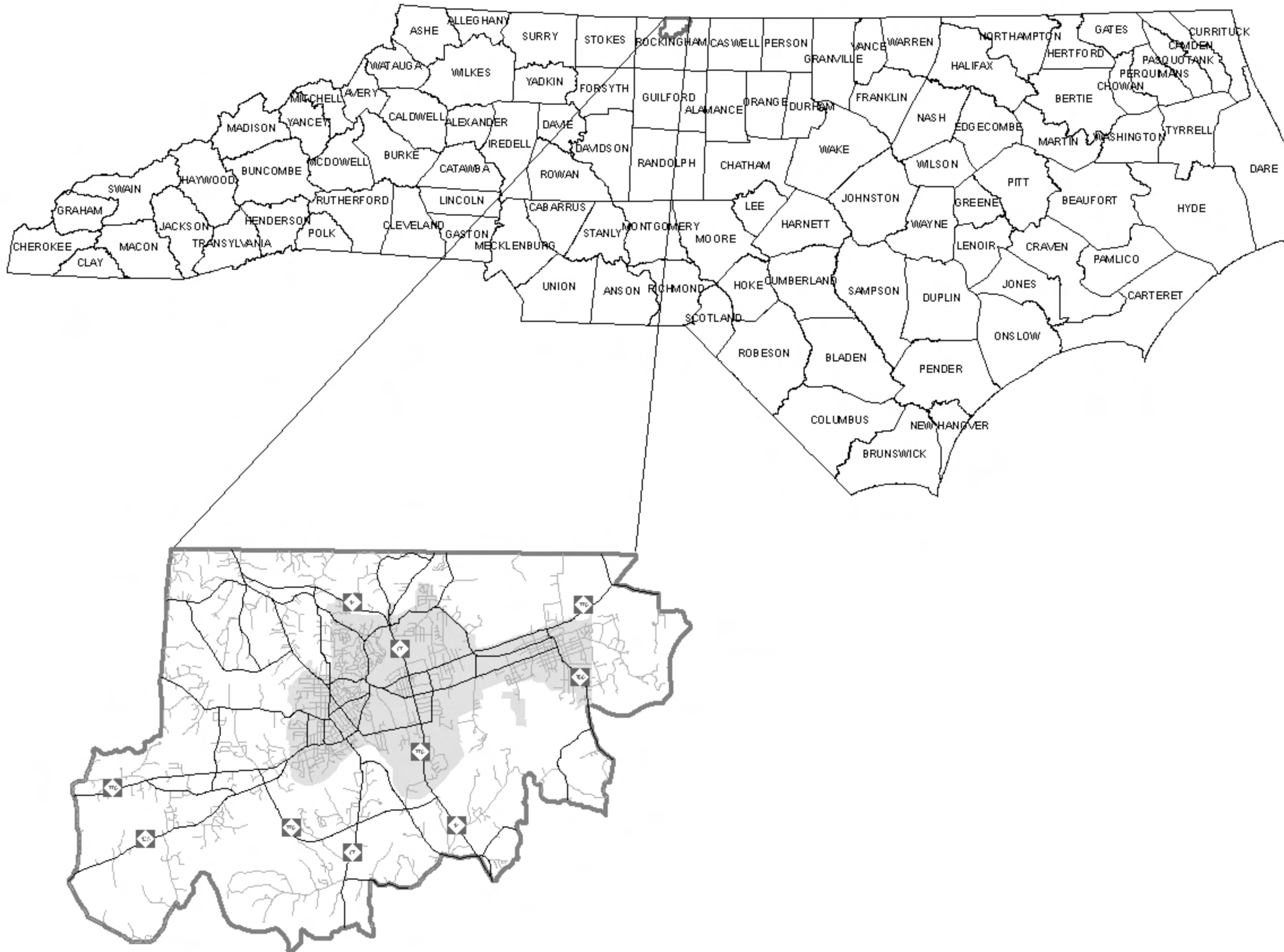

II. Recommendations

This chapter contains recommended improvements based on the ability of the existing transportation system to serve existing and anticipated travel desires as the area continues to grow. The recommended plan represents a system of transportation elements including highways, railroad, and bicycle facilities, which will serve the anticipated traffic and land development needs for the City of Eden Planning Area. The primary objective of this plan is to reduce traffic congestion and improve safety by eliminating both existing and projected deficiencies in the transportation system.

Highway Map

The recommended highway element of the Comprehensive Transportation Plan (CTP) for the City of Eden Planning Area is presented on Figure 1, Sheet 2. This plan includes roadways within the City of Eden Planning Area that fall into five categories: freeways, expressways, boulevards, other major thoroughfares, and other minor thoroughfares. See Appendix C for a detailed street tabulation and recommendations and Appendix D for definitions and figures of typical cross-sections.

The process of determining and evaluating recommendations for those roads in the transportation plan involves many considerations including: the goals and objectives of the public in the area, existing roadway properties, identified roadway capacity deficiencies, environmental impacts, and existing and anticipated land development. A transportation demand model (TDM) was developed to take into consideration the existing and anticipated land use. The TDM was used as a guide to identify existing and future roadway deficiencies. Consideration of these factors led to the cooperative development of several recommended improvements. A description of each recommendation follows:

Major Improvements

NC 14-87

- **Project Recommendation** – It is recommended that NC 14-87 throughout the planning area be improved to boulevard standards. The estimated cost of the project, including construction and right of way is \$53,400,000. This project includes the following upgrades:
 - **TIP Project R-4402** – NC 14-87 from the Virginia State Line to NC 700-770/SR 3003 (Meadow Road). Upgrade existing two and three lane facility to a four-lane divided facility. The estimated cost of the project, including construction and right of way is \$31,400,000.
 - NC 14-87-770 from NC 700-770/SR 3003 to NC 87/770. Change the current five-lane facility with center left-turn lane to a four-lane facility with a raised landscaped median and left-turn lanes installed at major points of activity. The estimated cost of the project, including construction and right of way is \$3,000,000.
 - NC 14-87-770 and SR 2066 (Kings Highway) intersection. Change the existing intersection with an eight-phase traffic signal to a diamond interchange. The estimated cost of this project, including construction and right of way is \$7,100,000.
 - NC 14-87-770 and NC 87-770 (Harrington Highway) intersection. Change the existing intersection with traffic signal to a partial clover-leaf interchange. The estimated cost of this project, including construction and right of way is \$9,600,000.
 - NC 14 from NC 87-770 to the southern planning area boundary. Change the current five-lane facility with center left-turn lane to a four-lane facility with raised median and left-turn lanes installed at major points of activity. The estimated cost of this project, including construction and right of way is \$2,300,000.
- **Transportation Demand** – The construction of these projects are needed to improve north-south travel from Martinsville, Virginia and destinations north through Eden to Greensboro and destinations south. In conjunction with being important on a regional level, this facility provides connections in and around the major commercial districts of Eden.
- **Roadway Capacity** – The 2007 Average Annual Daily Traffic (AADT) along NC 14-87 ranges from 14,000 vehicles per day (vpd) on the north end to 31,000 vpd in the center of Eden. The current capacity ranges from 17,300 vpd on the north end to 27,600 vpd in the center of Eden. The projected 2035 AADT ranges from 18,700 on the north end to 37,000 vpd in the center of Eden. NC 14-87 is currently operating between a Level of Service (LOS) D to E. Without improvements, portions of this facility will be operating at a LOS F by the year 2035. (See Chapter 4 for a detailed explanation of LOS.)

- **Safety Issues** – A total of 101 crashes occurred along the 9.08 mile stretch of NC 14-87 between January 1, 2005 and December 31, 2007. Seven intersections along this stretch are considered “high accident intersections”, 2 of which have a severity index rating higher than the state average. High crash locations are listed in Table 4 and shown visually in Figure 6.
- **Social Demands and Economic Development** – As identified in the City of Eden Land Development Plan, NC 14-87 is expected to be rural residential on the north side to the primary commercial center in the center of the city. The recommended improvements to this section of NC 14-87, in addition to accommodating the expected increase in traffic, may also help spur additional economic development in this area. This improvement may also provide better access to this commercial center, thereby making it more attractive for businesses to locate there.
- **System Linkage** – Improving the operational efficiency and safety of this section of NC 14-87 is imperative due to the significance of serving intra-city as well as regional travel, providing a connection from Eden to Virginia and the Triad area of North Carolina.
- **Relationship to Other Plans** – These improvements to NC 14-87 were identified in the 1997 City of Eden Thoroughfare Plan. The plan identified the need to widen the northern section of NC 14-87 from two-lanes to multi-lanes. This recommendation is an unfunded part of the 2009-2015 Transportation Improvement Program (R-4402).

NC 14-87 Bypass

- **Project Recommendation** – It is recommended that there be a NC 14-87 Bypass created from NC 87/SR 1605 (N. Oakland Ave) to NC 770 on the western side of the Eden Planning Area. This section should be a two-lane facility with 12-foot lanes. The estimated cost of this project, including construction and right of way is \$11,900,000. This project includes the following construction and upgrades:
 - SR 1605 (N. Oakland Ave) from NC 14-87 to SR 1557 (Westerly Park Rd). Resign existing facility as NC 14-87 Bypass.
 - SR 1557 (Westerly Park Rd) from SR 1605 to 0.7 miles south of SR 1605. Widen existing facility to two 12-foot lanes and resign as NC 14-87 Bypass.
 - New Location – SR 1557 (Westerly Park Rd) to NC 770. Construct a new facility with two 12-foot lanes and sign as NC 14-87 Bypass.

- **Transportation Demand** – This project is needed to improve north-south mobility through the City of Eden as well as to points north (Virginia) and south (Greensboro). It will serve as the western loop to the City of Eden. The traffic on existing NC 14-87 is expected to increase to 25,000-37,000 vpd by the year 2035.
- **Roadway Capacity** – The proposed capacity of the NC 14-87 Bypass is 13,000 vpd. Currently, NC 14-87-770 provides a capacity of 27,600 vpd. The 2007 projected volumes range from 22,000 to 31,000 vpd and 2035 projected volumes range from 25,000 to 37,000 vpd. Without the construction of this facility, the capacity would not be adequate to carry the projected 2035 daily volumes on existing NC 14-87.
- **System Linkage** – Improving the operational efficiency and safety of the entire section of NC 14-87 is imperative due to the significance of regional travel, providing a connection from Virginia to the Triad area of North Carolina. As this current section of NC 14-87 services a majority of the commercial needs for the City of Eden, it is essential that this recommended facility be constructed in order to accommodate the regional through traffic.
- **Relationships to Other Plans** – This project was identified in the 1997 City of Eden Thoroughfare Plan. The plan identified the need to create a two-lane bypass for NC 14-87.

Harrington Highway Eastern Extension

- **Project Recommendation** – It is recommended that Harrington Highway be extended from its current terminus with NC 14 east of existing SR 1951 (Quesinberry Rd) and continuing east onto NC 700. This section should be a two-lane facility with 12-foot lanes. The total cost of this project, including construction and right of way is \$10,100,000. This project includes the following construction and upgrades:
 - New Location – NC 14-87-770 to SR 1951 (Quesinberry Rd). Construct a new facility with two 12-foot lanes.
 - SR 1951 (Quesinberry Rd) from 0.55 miles west of NC 700 to NC 700. Widen existing facility to two 12-foot lanes.
- **Transportation Demand** – This project is needed to improve congestion on NC 14-87-770 through the primary commercial center of the City of Eden as well as to points in the eastern part of the city (SR 1747 – E. Stadium Drive). It will serve as the southern loop to the City of Eden.
- **Roadway Capacity** – The proposed capacity of the NC 14-87 Bypass is 13,000 vpd.

- **Social Demands and Economic Development** – The Harrington Highway Eastern Extension will provide connectivity between the city’s industrial area, Historic Downtown Draper, and NC 14, the primary connection to the Triad Region. Safe and efficient movement along this proposed route is imperative to Eden’s industrial growth, as identified in the Eden Land Use Plan. The proposed route may also help to spur other types of economic development in this area. This improvement may also provide better access to the primary industrial center, thereby making it more attractive for businesses to locate there.
- **System Linkage** – The Harrington Highway Eastern Extension will provide better connectivity from the eastern side of the city (Historic Downtown Draper) to NC 14, leading to the primary commercial area of Eden as well as to the Triad Region of North Carolina. As NC 14-87-770 and SR 1747 (E. Stadium Drive) services the majority of east to south flow within the City of Eden, it is essential that the proposed facility be able to accommodate traffic from the eastern side of the city to its primary commercial center as well as to the Triad Region of North Carolina.

Currently, Harrington Highway from NC 770 to NC 14 is a two-lane partially-controlled access facility with a four-lane right-of-way. Providing the same level of access control on the proposed extension will ensure connectivity between the existing and proposed facilities.

- **Relationships to Other Plans** – The proposed Harrington Highway Eastern Extension was identified in the 1997 City of Eden Thoroughfare Plan.

West Draper Spur

- **Project Recommendation** – It is recommended that a new route be constructed from NC 700 to the Harrington Highway Eastern Extension. This section should be a two-lane facility with 12-foot lanes. The estimated cost of this project, including construction and right of way is \$15,700,000.
- **Transportation Demand** - This project is needed to improve congestion on NC 14-87-770 through the primary commercial center of the City of Eden as well as to points in the eastern part of the city (SR 1747 – E. Stadium Drive). It provides an additional north-south connector for the eastern side of the city.
- **Roadway Capacity** – The proposed capacity of the West Draper Spur is 13,000 vpd.
- **Social Demands and Economic Development** – The West Draper Spur will provide connectivity between the city’s industrial area and NC 14, the primary connection to the Triad Region. Safe and efficient movement along this

proposed route is imperative to Eden's industrial growth, as identified in the Eden Land Use Plan. The proposed route may also help to spur other types of economic development in this area. This improvement may also provide better access to the primary industrial center, thereby making it more attractive for businesses to locate there.

- **System Linkage** – The West Draper Spur will provide better connectivity from the industrial side of the city to NC 14, leading to the primary commercial area of Eden as well as to the Triad Region of North Carolina. This proposed north-south connector from NC 770 to the proposed Harrington Highway Eastern Extension will be able to accommodate traffic from the eastern side of the city to its primary commercial center as well as to the Triad Region of North Carolina.
- **Relationships to Other Plans** – The proposed West Draper Spur was identified in the 1997 City of Eden Thoroughfare Plan.

SR 2066 (W. Kings Hwy)

- **Project Recommendation** – It is recommended that SR 2066 (W. Kings Highway) from SR 1604 (Washington St) to NC 14-87-770 be changed from the current five-lane facility with center left-turn lane to a four-lane facility with raised median and left-turn lanes installed at major points of activity. The estimated cost of this project, including construction and right of way is \$1,200,000.
- **Transportation Demand** – This project is needed to improve the east-west mobility through the City of Eden. The traffic on SR 2066 (W. Kings Highway) is expected to increase from 17,000 vpd in 2007 to 24,900 vpd by 2035.
- **Roadway Capacity** – Currently, SR 2066 (W. Kings Highway) has a capacity of 26,100 vpd. Without improvements, the existing capacity would be barely adequate to carry the projected 2035 volumes on SR 2066 (W. Kings Highway) and function at a LOS D.
- **Safety Issues** – SR 2066 (W. Kings Highway) is located within the heart of commercial development in the City of Eden. With many traffic signals and curb cuts, SR 2066 (W. Kings Highway) experiences congestion as well as an increased risk for traffic crashes. A total of 68 crashes occurred along the 0.92 mile stretch of SR 2066 (W. Kings Highway) between January 1, 2005 and December 31, 2007. Five intersections along this stretch are considered “high accident intersections”, 1 of which has a severity index rating higher than the state average.
- **Social Demands and Economic Development** – As identified by the City of Eden Land Development Plan, SR 2066 (W. Kings Highway) is expected to

be near the primary commercial center of the city. The recommended improvements to SR 2066 (W. Kings Highway), in addition to accommodating the expected traffic increase, may also help to spur economic development in this area. This improvement may also provide better access to this commercial center, thereby making it more attractive for businesses to locate there.

- **System Linkage** – Improving the operational efficiency and safety of SR 2066 (W. Kings Highway) is imperative due to the significance of serving intra-city travel, providing a connection from the Leaksville and Spray areas to the primary commercial center.

SR 3003 (W. Meadow Road)

- **Project Recommendation** – It is recommended that SR 3003 (W. Meadow Road) from SR 3002 (Boone Road) to SR 1747 (Stadium Drive) be widened from the current two-lane facility to a four-lane facility, including the addition of a new bridge. The estimated cost of this project, including construction and right of way is \$8,700,000.
- **Transportation Demand** – This project is needed to improve the east-west mobility through the City of Eden. The traffic on this section of SR 3003 (W. Meadow Road) is expected increase from 11,900 vpd in 2007 to 20,700 vpd by 2035.
- **Roadway Capacity** – Currently, this section of SR 3003 (W. Meadow Road) is a two-lane facility, providing a capacity of 12,100 vpd. SR 3003 (W. Meadow Road) is currently operating between a LOS C to D. Without improvements, portions of this facility will be operating as high as LOS F by the year 2035.
- **Social Demands and Economic Development** – As identified by the City of Eden Land Development Plan, SR 3003 (W. Meadow Road) is expected to be near the primary redevelopment area of the city. The recommended improvements to SR 3003 (W. Meadow Road), in addition to accommodating the expected traffic increase, may also help to spur economic development in this area. This improvement may also provide better access to this redevelopment center, thereby making it more attractive for businesses to locate there.
- **System Linkage** – Improving the operational efficiency and safety of this section of SR 3003 (W. Meadow Road) is imperative due to the significance of serving intra-city travel, providing a connection from the Leaksville and Spray areas to NC 14-87.

- **Relationships to Other Plans** – The improvements on this section of SR 3003 (W. Meadow Road) support those developed as part of the 1997 City of Eden Thoroughfare Plan, which identified the need to have an additional bridge in this area. While the 1997 Thoroughfare Plan identified a bridge to SR 3002 (Boone Road), this recommendation is more feasible as it will provide an additional bridge within the state’s current right-of-way.

SR 1714 (E. Aiken Road)

- **Project Recommendation** – It is recommended that SR 1714 (East Aiken Road) be realigned on a new location from SR 1716 (Virginia Street) to SR 1797 (Friendly Road N.). This section should be a two-lane facility with 12-foot lanes. The existing facility will remain for local access. The estimated cost of this project, including construction and right of way is \$2,700,000.
- **Safety Issues** – This section of SR 1714 (E. Aiken Road) is located in North Eden. Traffic along this route experiences many sharp curves and vertical decline over a short distance, causing vehicles to either cross over into an oncoming lane or off the road all together. Due to these factors, there is a much greater risk of higher speeds than the posted speed limit as well as head-on collisions. A total of five crashes occurred along the 1.04 mile stretch of SR 1714 (E. Aiken Road) between January 1, 2005 and December 31, 2007.
- **System Linkage** – The realignment of SR 1714 (E. Aiken Road) should provide better connectivity between NC 700-770 and NC 14-87.
- **Relationships to Other Plans** – recommended realignment of this section of SR 1714 (E. Aiken Road) was identified in the 1997 City of Eden Thoroughfare Plan.

SR 1708 (Bryant Street)

- **Project Recommendation** – It is recommended that SR 1708 (Bryant St.) be realigned from SR 1708 (Bryant Street) to SR 1709 (N. Hamilton Street). This section should be a two-lane facility with 12-foot lanes. The estimated cost of this project, including construction and right of way is \$750,000.
- **System Linkage** – The realignment of SR 1708 (Bryant St) should improve connectivity from the north side of Eden to the Downtown Areas of Leaksville and Spray by eliminating two existing intersections.
- **Relationships to Other Plans** – The realignment of this section of SR 1708 (Bryant St.) was identified in the 1997 City of Eden Thoroughfare Plan.

Minor Widening Improvements

The following routes do not have capacity issues, but are recommended to be upgraded to two 12-foot lanes with 2-foot paved shoulders to improve safety.

- **US 311/NC 135:** It is recommended that US 311/NC 135 be widened from two 10-foot lanes to two 12-foot lanes from the Eden PAB to NC 770.
- **NC 770:** It is recommended that NC 770 be widened from two 10-foot lanes to two 12-foot lanes from the SR 1737 (Main Street) to SR 1743 (Gant Road).
- **SR 1535 (Price Road/Center Church Road):** It is recommended that SR 1535 be widened from two 10-foot lanes to 12-foot lanes from the Eden PAB to Price Street.
- **SR 1553 (Rhodes Road):** It is recommended that SR 1553 be widened from two 9-foot lanes to 12-foot lanes from SR 1501 (Garrett Road) to SR 1605 (N. Oakland Ave).
- **SR 1716 (Virginia Street):** It is recommended that SR 1716 be widened from two 9-foot lanes to 12-foot lanes from the Virginia State Line to SR 1709 (Lincoln Road – Southern Terminus).
- **SR 2881 (Old NC 135):** It is recommended that SR 2881 be widened from two 10-foot lanes to two 12-foot lanes from NC 770 to SR 1604 (Washington Street).

Other Improvements

US 311 Signage

US 311 has been approved to be signed through Eden. Its current signed terminus is at US 220 in the Madison-Mayodan area. Its approved signed terminus is at NC 14 using NC 135 to NC 770 (Harrington Highway). When funds become available, US 311 will be signed using these routes.

Public Transit and Rail Map

The recommended public transit and rail element of the Comprehensive Transportation Plan (CTP) for the City of Eden Planning Area is presented on Figure 1, Sheet 3.

Rockingham County is currently served by the Rockingham Public Access Transportation, a private non-profit operating under the Rockingham County Council of Aging, Inc. This non-profit organization serves human service agencies throughout the county. It also serves the general public through subscription and dial-a-ride routes throughout the county.

Currently, there is no fixed-route bus system serving the City of Eden. While no recommendation is made in this transportation plan, future plans may consider fixed-route service linking Eden with Reidsville, Wentworth, and the rest of the Triad. This may consist of a partnership with Rockingham Public Access Transportation and/or the Piedmont Authority for Regional Transportation (PART).

Currently, there is one rail line that runs into the City of Eden. The Carolina and Northwestern Railway operates one active line into the city from Virginia. There are no plans for this to be a commuter rail corridor.

The CTP process identified several potential locations for park and ride lots. These locations have been identified to serve as a carpool/vanpool meeting point for commutes to different metropolitan areas outside the City of Eden. The following locations are recommended from a systems perspective, but final locations would be subject to agreements with property owners, etc.

- Proposed Park and Ride Lot on SR 1604 (Washington Street) at NC 770. This could serve commutes to the west of the planning area (i.e. Winston-Salem).
- Proposed Park and Ride Lot on NC 14-87-770 (Van Buren Road) at SR 1964 (Mebane Bridge Road). This could serve commutes to the south of the planning area (i.e. Reidsville, Greensboro).
- Proposed Park and Ride Lot on South Avenue, near NC 700. This could serve commutes to the northeast of the planning area (i.e. Danville, VA)

Bicycle Map

The NCDOT envisions that all citizens of North Carolina and visitors to the state should be able to walk and bicycle safely and conveniently to their chosen destinations with reasonable access to roadways. Information on events, funding, maps, policies, projects, and processes dealing with these modes of transportation can be accessed at the Division of Bicycle and Pedestrian Transportation's web site. Refer to Appendix A for contact information.

The recommended bicycle element of the Comprehensive Transportation Plan (CTP) for the City of Eden Planning Area is presented on Figure 1, Sheet 4. In 2005, the Piedmont-Triad RPO completed their RPO Bicycle Study for the region, including the CTP study area. The facilities identified by the Bicycle Study were incorporated as part of the Bicycle Plan for the City of Eden CTP. In 2007, the City of Eden completed their Greenway Master Plan. The facilities identified by the Greenway Master Plan, both on and off-road, were incorporated as part of the Bicycle Plan for the City of Eden CTP. Before any improvements are made to these facilities, the Division of Bicycle and Pedestrian Transportation should be consulted.

The following on-road network bicycle facilities have been identified as needing improvement in the City of Eden CTP.

- NC 14-87 from SR 1700 (Fisher Hill Road) to SR 1714 (Aiken Road)
- NC 87 from SR 2105 (Yount Road) to SR 2203 (Ashley Loop Road)
- NC 700-770 from SR 1962 (Pierce Street) to SR 1714 (Summit Road)
- NC 700 from NC 770 (E. Meadow Road) to Front Street
- NC 700 from SR 1737 (Main Street) to Eden Planning Area Boundary
- NC 770 from SR 1604 (Washington Street) to SR 2039 (Bethlehem Church Road)
- NC 770 from SR 1737 (Main Street) to Eden Planning Area Boundary
- SR 1501 (Garrett Road) from Eden Planning Area Boundary to SR 1605 (N. Oakland Ave.)
- SR 1535 (Price Road & Center Church Road) from Eden Planning Area Boundary to SR 1561 (S. Hamilton Street)
- SR 1561 (S. Hamilton Street) from Early Ave. to SR 1535 (Center Church Road)
- SR 1604 (Washington Street) from SR 2281 (Old NC 135) to SR 1605 (N. Bridge Street)
- SR 1700 (Fisher Hill Road) from NC 14-87 to SR 3004 (Morgan Road)
- SR 1714 (Bryant Street) from SR 3004 (Morgan Road) to SR 1710 (Lake Drive)
- SR 1714 (W. Aiken Road) from SR 3004 (Morgan Road) to NC 14-87
- SR 1743 (Gant Road) from NC 770 to Eden Planning Area Boundary
- SR 1747 (E. Stadium Drive) from NC 14-87-770 to Edgewood Road

- SR 1945 (Moir Hill Road) from SR 2039 (Bethlehem Church Road) to Eden Planning Area Boundary
- SR 1962 (N. Pierce Street) from NC 700-770 to SR 1747 (E. Stadium Drive)
- SR 1962 (S. Pierce Street) from SR 1747 (E. Stadium Drive) to SR 2066 (E. Kings Highway)
- SR 2039 (Bethlehem Church Road) from SR 2282 (S. Hamilton Street) to SR 1945 (Moir Hill Road)
- SR 2066 (W. Kings Highway) from SR 2066 (Bridge Street) to NC 14-87-770
- SR 2066 (E. Kings Highway) from NC 14-87-770 to SR 1962 (S. Pierce Street)
- SR 2203 (Ashley Loop Road) from NC 87 to Eden Planning Area Boundary
- SR 2282 (S. Hamilton Street) from SR 1604 (Hamilton Street) to SR 2039 (Bethlehem Church Road)
- SR 3002 (Boone Road) from SR 1605 (Bridge Street) to SR 3003 (W. Meadow Road)
- SR 3003 (Church Street) from SR 3004 (Morgan Road) to SR 1747 (W. Stadium Drive)
- SR 3004 (Morgan Road) from SR 1605 (N. Oakland Ave.) to SR 3003 (Church Street)
- Early Ave from SR 1561 (S. Hamilton Street) to Greenwood Street
- N. Edgewood Road from NC 700 to SR 1747 (E. Stadium Drive)
- Main Street from NC 770 to NC 700

Other proposed bicycle facilities and recommended improvements, on and off-road, were identified in the Eden Greenway Master Plan. These improvements are not a part of the City of Eden Comprehensive Transportation Plan network. Please refer to the Eden Greenway Master Plan for more information on these recommendations.

Recommended bicycle improvements should be incorporated as roadway improvements are implemented and as funding is available.

Pedestrian Map

The format for the Comprehensive Transportation Plan Pedestrian Map is still under development; therefore no map was included.

III. Implementation

Implementation is one of the most important aspects of the comprehensive transportation plan. If implementation is not an integral part of this process, the effort and expense associated with developing the plan will be lost. There are several tools available for use by the City to assist in the implementation of the CTP. They are described in detail in this chapter.

State-City Adoption of the CTP

The City of Eden and the North Carolina Department of Transportation have mutually approved the CTP shown in Figure 1. The mutually adopted plan can now serve as a guide for the Department of Transportation in the development of the transportation system for Eden. The approval of this plan by the City of Eden also enables standard road regulations and land use controls to be used effectively in the implementation of this plan. As part of the plan, the City of Eden and NCDOT shall reach agreement on the responsibilities for existing and proposed streets and highways. Facilities which are designated a State responsibility will be constructed and maintained by the Division of Highways.

Methods Used to Protect the Adopted CTP

Subdivision Regulations

Subdivision regulations require every subdivider to submit to the City Planning Board a plan of any proposed subdivision. It also requires that subdivisions be constructed to meet certain standards. Through this process, it is possible to require the subdivision streets to conform to the CTP and to reserve or protect necessary right-of-way for proposed roads and highways that are a part of the CTP.

The construction of subdivision streets to adequate standards reduces maintenance costs and simplifies the transfer of streets to the State Highway System. Appendix E outlines the recommended subdivision design standards as they pertain to road construction.

Zoning Ordinances

A zoning ordinance can be beneficial to transportation planning by designating appropriate locations of various land use and allowable densities of residential development. This provides a degree of stability on which to make future traffic projections and to plan streets and highways.

Other benefits of good zoning ordinance are: (1) the establishment of standards of development which will aid traffic operations on major thoroughfares and (2) the minimization of strip commercial development which creates traffic friction and increases the traffic accident potential.

Future Street Line Ordinances

A municipality with legislative approval may amend its charter to be empowered to adopt future street line ordinances. This ordinance, enacted for selected streets, is particularly beneficial for planned future improvements, such as roadway widening. Through a metes-and-bounds description of a street's future right-of-way requirements, the municipality may prohibit new construction or reconstruction of structures within the future right-of-way. This approach requires specific design hearings to be held as an opportunity for affected property owners to obtain information about what to expect and to make necessary adjustments without undue hardship.

Roadway Corridor Official Maps

A Roadway Corridor Official Map (Official Map) is a document adopted by the North Carolina Board of Transportation (NCBOT) which allows the reservation of roadway corridors as provided by General Statutes 136-44.50 through 136-44.54. Official Maps place temporary restrictions on private property rights by prohibiting the issuance of a building permit or the approval of a subdivision on property within an adopted alignment, for up to a three-year period beginning when a request for development is denied. The Official Map in effect serves as notice to developers that the State or Municipality intends to acquire specific property. This process is a beneficial tool in directing development so those sites can be reserved for public improvements in anticipation of actual need.

Development Reviews

The District Engineer's Office and the Traffic Engineering Branch of the North Carolina Department of Transportation review driveway access to any state-maintained road. In addition, any development expected to generate large volumes of traffic (e.g., shopping centers, fast food restaurants, or large industries) should be comprehensively studied by the Traffic Engineering Branch, the Project Development and Environmental Analysis Branch, and/or the Roadway Design Unit of NCDOT. If reviewed at an early stage, it is often possible to significantly improve the development's accessibility while preserving the integrity of the CTP.

Funding Sources

Capital Improvements Program

A capital improvement program makes it easier to build a planned transportation system. It consists of two lists of projects. The first is a list of highway projects that are designated as a municipal responsibility and are to be implemented with municipal funds. The second is a list of local projects designated as State responsibility to be included in the State's Transportation Improvement Program.

Transportation Improvement Program

North Carolina's Transportation Improvement Program (TIP) is a document that lists all major transportation projects, and their funding sources, planned by the NCDOT for a seven-year period. Every two years, when the TIP is updated, completed projects are removed, programmed projects are advanced, and new projects are added.

During biennial TIP public hearings, municipalities, local citizens groups, Rural Planning Organizations (RPO), and other interested parties request projects to be included in the TIP. The group requesting a particular project(s) should submit to the NCDOT Board of Transportation Member representing their area the following: a letter with a prioritized summary of requested projects, TIP candidate project request forms, and project location maps with a description of each project. Refer to Appendix I for an example of a TIP project request package. Local areas should work within their respective Rural Planning Organization (RPO) to develop local and regional project priorities.

The Board of Transportation reviews all of the project requests from each area of the state. Based on the technical feasibility, need, and available funding, the board decides which projects will be included in the TIP. In addition to highway construction and widening, TIP funds are available for bridge replacement, highway safety projects, public transit projects, railroad projects and bicycle facilities.

Industrial Access Funds

If certain economic conditions are met, Industrial Access Funds are available for construction of access roads for industries that plan to develop property that does not have access to any state-maintained road. The NCDOT Secondary Roads Office should be contacted for information on Industrial Access Funds.

Small Urban Funds

Small Urban Funds are annual discretionary funds that are made available to municipalities with qualifying projects on the state system. The maximum amount is one million dollars per year per highway division. Requests for Small Urban Fund assistance should be directed to the Division Engineer or to the Program Development Branch of NCDOT.

Implementation Recommendations

The following table gives recommendations for the most suitable funding sources and methods of implementation for the major project proposals of the City of Eden CTP.

Projects	Funding Sources				Methods of Implementation				
	Local Funds	TIP Funds	Indust. Access	Small Urban	CTP	Subdiv. Ord.	Zoning Ord.	Future Street Lines	Develop Review
NC 14-87 (R-4402)		X			X		X	X	X
NC 14-87 (Access Mgmt)		X			X		X	X	X
NC 14-87 (Interchanges)		X			X		X	X	X
NC 14-87 (Bypass)		X			X		X	X	X
SR 2066 (Access Mgmt)		X			X		X	X	X
SR 3003 (Access Mgmt)		X			X		X	X	X
Harrington Hwy (East Ext)		X	X	X	X		X	X	X
West Draper (Spur)		X	X	X	X		X	X	X

IV. Population, Land Use, and Traffic

In order to fulfill the objectives of an adequate long-range transportation plan, reliable forecasts of future travel patterns must be achieved. Such forecasts depend on careful analysis of the following items:

- Historic and potential population changes
- Significant economic trends
- Character and intensity of land development
- The ability of the existing transportation system to meet existing and future travel demand

Secondary items that influence forecasts include the following items:

- Effects of legal controls such as zoning ordinances and subdivision regulations
- Availability of public utilities and transportation facilities
- Topographic and other physical features of the area

Population

Since the volume of traffic on a roadway is related to the size and distribution of the population it serves, population data is used to aid in the development of the transportation plan. Future population estimates typically rely on the observation of past population trends and counts. Table 2 presents the population trend for the City of Eden, Rockingham County, and North Carolina.

Table 2: Population Growth							
Location	1980	1990	2000	2007	2010	2020	2030
North Carolina	5,880,095	6,632,448	8,046,491	9,069,398*	9,349,175*	10,709,704*	12,447,597*
Rockingham County	83,426	86,064	91,928	91,646*	91,485*	90,830*	89,836*
City of Eden	15,672	15,238	15,908	15,666*	16,055**	16,363**	16,599**

Source: North Carolina State Data Center

* Projections by the North Carolina State Data Center

** Projections for Eden provided by the NCDOT Transportation Planning Branch

Land Use

Land use refers to the physical patterns of activities and functions within an area. The generation and attraction of trips created by the land use along a particular transportation facility are related to the types of land use adjacent to that facility and the intensity of land use affects the traffic patterns for multi-modal facilities. For instance, a shopping center generates larger traffic volumes than does a residential neighborhood. The spatial distribution of varying land uses is the predominant determinant of when, where, and why congestion occurs. The attraction between different land uses and their association with travel varies with the size, type, intensity, and spatial separation of each land use.

For transportation planning purposes, land use is typically divided into the following classifications:

- **Residential**: All land is devoted to the housing of people, with the exception of hotels and motels.
- **Commercial**: All land is devoted to retail trade including consumer and business services and their offices; this may be further stratified into retail and special retail classifications. Special retail would include high-traffic establishments, such as fast food restaurants and service stations; all other commercial establishments would be considered retail.
- **Industrial**: All land is devoted to the manufacturing, storage, warehousing, and transportation of products.
- **Public**: All land is devoted to social, religious, educational, cultural, and political activities; this would include the office and service employment establishments.
- **Agricultural**: All land is devoted to the use of buildings or structures for the raising of non-domestic animals and/or growing of plants for food and other production.

Projections of future land use for this study were based on the City of Eden Land Development Plan. Existing Land Use for the City of Eden is shown in Figure 3. Figure 4 shows the future land use and Figure 5 shows the Growth Strategy for the City of Eden.

Population and Employment Projections for the Planning Area are provided in Appendix F.

Figure 3: City of Eden Existing Land Use

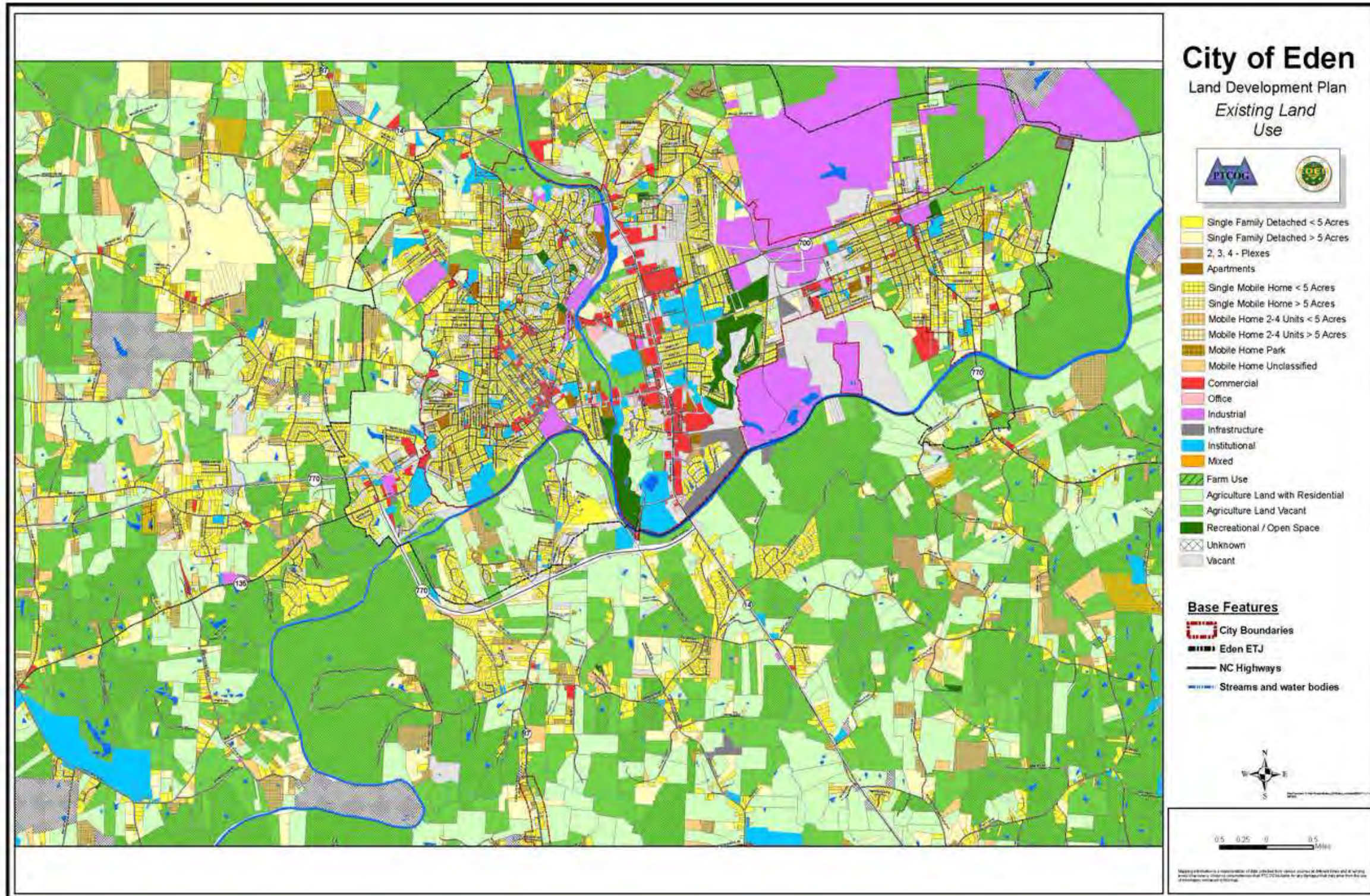

Figure 4: City of Eden Future Land Use

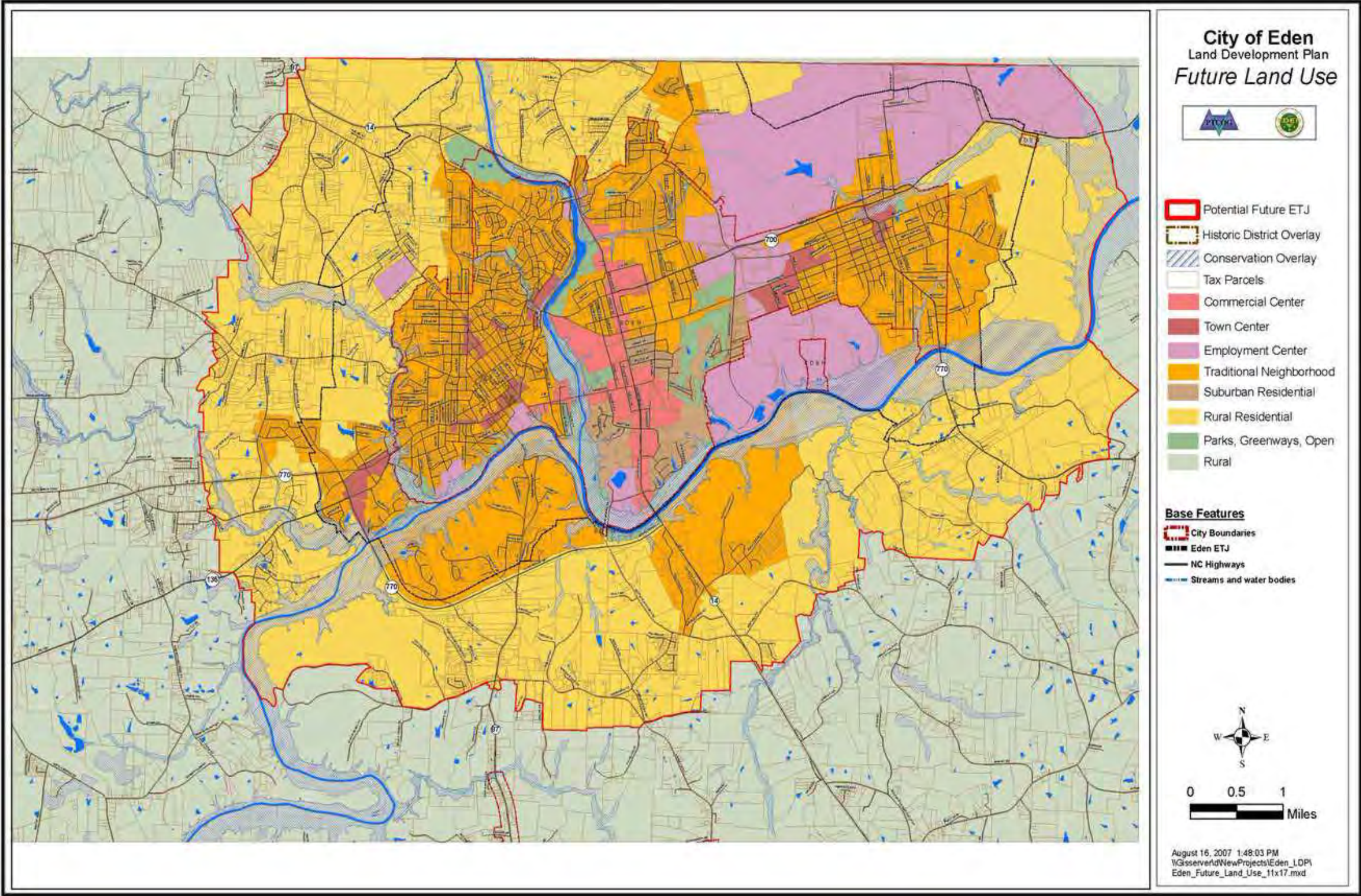
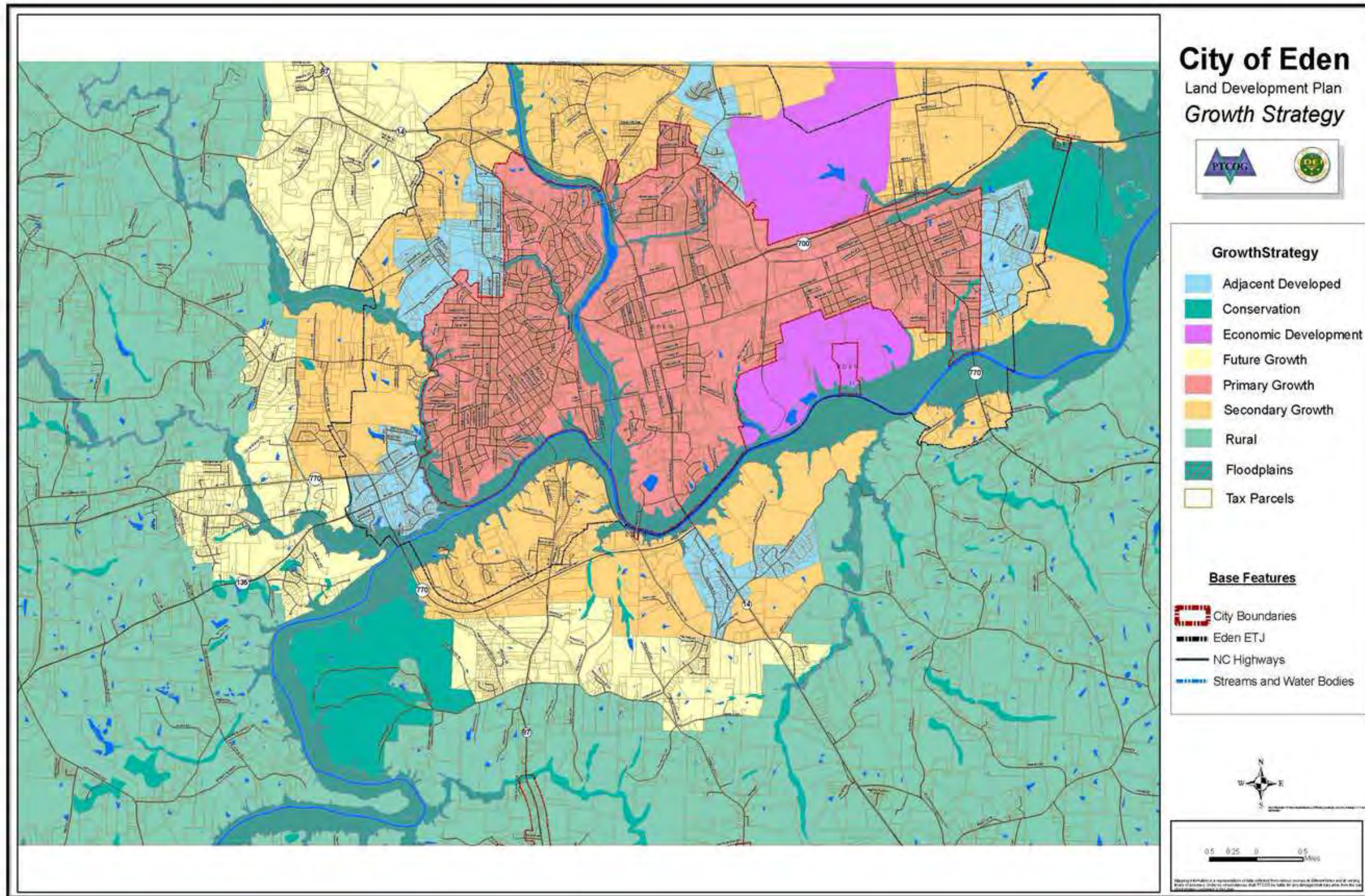

Figure 5: City of Eden Growth Strategy



Roadway System

An important stage in the development of a CTP is the analysis of the existing roadway system and its ability to serve the area's travel desires. Emphasis is placed not only on detecting the existing deficiencies, but also on understanding the causes of these deficiencies. Roadway deficiencies may result from inadequacies such as pavement widths, intersection geometry, or intersection controls. Deficiencies may also result from system problems, such as the need to construct missing travel links, bypass routes, loop facilities, or additional radial routes.

An analysis of the roadway system looks at both current and future travel patterns and identifies existing and anticipated deficiencies. This is usually accomplished through a traffic crash analysis, roadway capacity deficiency analysis, and a system deficiency analysis. This information, along with population growth, economic development potential, and land use trends, is used to determine the potential impacts of the future system.

Traffic Crash Analysis

Traffic crashes are often used as an indicator for locating congestion and roadway problems. While often the result of driver error or vehicle malfunction, crashes may also be a result of the physical characteristics of the roadway. Deficiencies such as poor design and obstructions, traffic conditions, limited sight distance and inadequate signing may all lead to a crash. Crash patterns obtained from an analysis of crash data can lead to the identification of improvements that will reduce the number of crashes.

Crash data for the period of January 1, 2005 to December 31, 2007 was studied as part of the development of this report. The crash analysis considered both crash frequency and severity. Crash frequency is the total number of reported crash, while crash severity is the crash rate based upon injuries and property damage incurred.

The severity of every accident is measured with a series of weighting factors developed by the NCDOT Division of Highways (DOH). These factors define a fatal or incapacitating crash as 47.7 times more severe than one involving only property damage, and an accident resulting in minor injury is 11.8 times more severe than one with only property damage. In general, a higher severity index indicates more severe accidents. Table 3 lists the levels of severity for various severity index ranges.

Table 3: Severity Index	
Severity	Severity Index
Low	< 6.0
Average	6.0-7.0
Moderate	7.0-14.0
High	14.0-20.0
Very High	> 20.0

Table 4 depicts a summary of the crashes occurring in the planning area between January 1, 2005 and December 31, 2007. The data represents locations with 5 or more crashes and/or a severity average greater than that of the state's 4.87 index. The "Total" column indicates the total number of accidents reported within 150-ft of the intersection during the study period. The severity listed is the average crash severity for that location. The crash locations are displayed in Figure 6.

The NCDOT is actively involved with investigating and improving many of these locations. To request a more detailed analysis for any of the locations listed in Table 4, or other intersections of concern, contact the Division Traffic Engineer. Contact information for the Division Traffic Engineer is included in Appendix A.

Table 4: Severity Index at High Crash Locations

Map Index	Road A	Road B	Severity Index	Number of Crashes
1	NC 770	SR 1533	16.06	7
2	BRIDGE ST	KINGS HWY	15	7
3	NC 87	NC 770	10.06	10
4	ARBOR LN	NC 14-87-770	7.86	24
5	KENNEDY ST	KINGS HWY	7.47	14
6	DEVONWAY ST	NC 14-87-770	6.92	5
7	FIELDCREST RD	STADIUM DR	6.29	7
8	HARRIS PL	NC 14-87-770	6.18	10
9	NC 87	ASHLEY LOOP RD	5.45	17
10	STADIUM DR	NC 14-87-770	5.44	15
11	AIKEN RD	CHATHAM CT	5.44	5
12	NC 135	NC 770	5.32	12
13	MEADOW RD	PIERCE ST	4.7	8
14	JAY ST	PATRICK ST	4.7	6
15	AIKEN RD	NC 14-87	4.7	10
16	PIERCE ST	STADIUM DR	4.29	9
17	BRIDGE ST	EARLY AVE	4.29	9
18	ARBOR LN	LINDEN DR	4.17	7
19	HAMILTON ST	WASHINGTON ST	3.96	5
20	CHURCH ST	OAKLAND AVE	3.47	6
21	PATRICK ST	WASHINGTON ST	3.11	7
22	FAGG DR	KINGS HWY	3.11	7
23	KINGS HWY	NC 14-87-770	2.95	34
24	NC 14	NC 87-770	2.85	12
25	HENRY ST	WASHINGTON ST	2.85	8
26	BOONE RD	MEADOW RD	2.48	5
27	AIKEN RD	MORGAN RD	2.48	5
28	BRIDGE ST	WASHINGTON ST	2.23	6
29	EARLY AVE	MOIR ST	1	5
	Totals			224

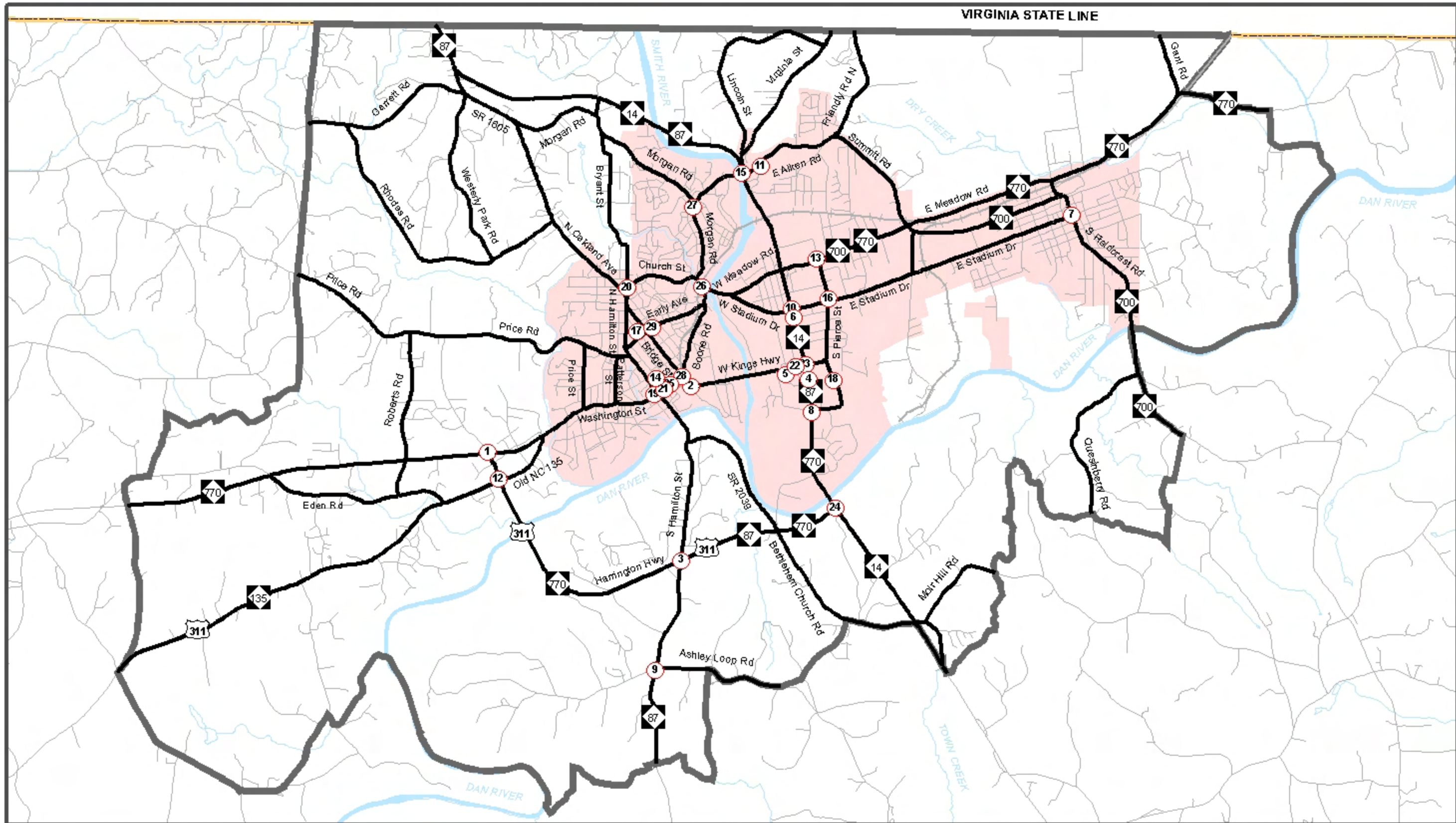

VIRGINIA STATE LINE

Base map date: September 2007



Legend

- 1 Accident Locations
- Network Roads
- Other Roads
- Planning Boundary
- County Boundary
- City Limits

City of Eden
Figure 6:
Crash Locations
 January 1, 2005 to
 December 31, 2007

Bridge Conditions

Bridges are an important element of a highway system. Any bridge deficiency will affect the efficiency of the entire transportation system. In addition, bridges present the greatest threat of community disruption and loss of life of any potential highway failure. Therefore, bridges must be constructed to the same, or higher, design standards as the highway system of which they are a part, and they must be inspected regularly to ensure the safety of the traveling public.

The NCDOT Bridge Maintenance Unit inspects all bridges in North Carolina at least once every two years. A sufficiency rating for each bridge is calculated and establishes the eligibility and priority for bridge replacement. Bridges with the highest priority are replaced as Federal and State funds become available.

A bridge is considered deficient if it is either structurally deficient or functionally obsolete. A bridge at least ten years old is considered structurally deficient if it is in relatively poor condition or has insufficient load-carry capacity, due either to the original design or deterioration. A bridge is considered to be functionally obsolete if it is narrow, has inadequate under-clearances, has insufficient load-carrying capacity, is poorly aligned with the roadway, or can no longer adequately serve existing traffic. A bridge must be classified as deficient in order to qualify for Federal replacement funds, in addition to having a qualifying sufficiency rating. To qualify for replacement, the sufficiency rating must be less than 50%; for rehabilitation, the sufficiency rating must be less than 80%. Deficient bridges in City of Eden Planning Area are listed in Table 5 and the locations of these bridges are shown in Figure 7.

Bridge Number	Route	Across	Structurally Deficient	Functionally Obsolete
69	SR 2221 (Eden Road)	Buffalo Creek	Yes	No
71	SR 1951 (Quesinberry Road)	Creek	Yes	No
76	SR 1951 (Quesinberry Road)	Prong Town Creek	Yes	No
108	NC 700-770 (Meadow Road)	NC 14-87	Yes	No
134	NC 700 (Fieldcrest Road)	Dan River	Yes	No
177	SR 1535 (Price Road)	Matrimony Creek	No	Yes
253	SR 1747 (E. Stadium Drive)	Southern Railway	Yes	No

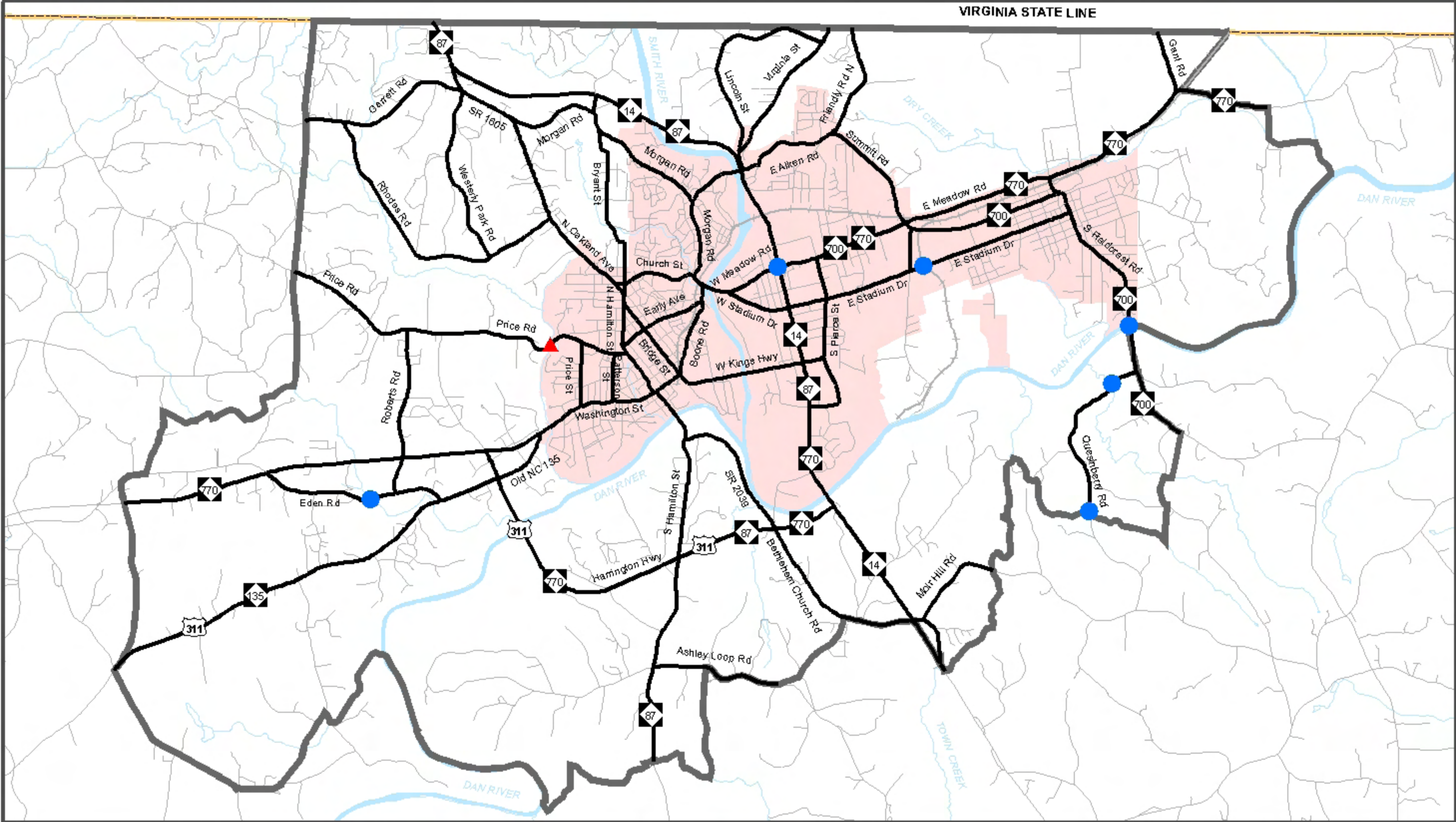

Legend

- ▲ Functionally Obsolete Bridges
- Structurally Deficient Bridges
- Network Roads

- Planning Boundary
- Rockingham Boundary
- City Limits

City of Eden
Figure 7:
Structurally Deficient and
Functionally Obsolete Bridges

Base map date: September 2007

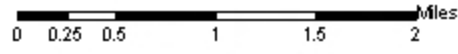

Roadway Capacity Deficiencies

Capacity deficiencies occur when the traffic volume of a roadway is eighty percent or more of roadway's capacity. Travel volumes are based on the total number of vehicles that use a roadway on a typical day. These volumes are based on annual average daily traffic (AADT) counts taken annually by the NCDOT Traffic Survey Group.

Capacity is the maximum number of vehicles which have a "reasonable expectation" of passing over a given section of roadway, during a given time period under prevailing roadway and traffic conditions. Many factors contribute to the capacity of a roadway including the following:

- Geometry of the road, including number of lanes, horizontal and vertical alignment, and proximity of perceived obstructions to safe travel along the road;
- Typical users of the road, such as commuters, recreational travelers, and truck traffic;
- Access control, including streets and driveways, or lack thereof, along the roadway;
- Development of the road, including residential, commercial, agricultural, and industrial developments;
- Number of traffic signals along the route;
- Peaking characteristics of the traffic on the road;
- Characteristics of side-roads feeding into the road; and
- Directional split of traffic or the percentages of vehicles traveling in each direction along a road at any given time.

2007 Traffic Capacity Analysis

A comparison of the 2007 travel demand volumes for the major roadways in the planning area and their respective capacities identified several existing deficiencies for the City of Eden planning area. These existing roadway deficiencies are summarized in Table 6 and shown in Figure 8.

2035 Traffic Capacity Analysis

The capacity deficiency analysis for the 2035 design year is based upon a "no build" scenario. This analysis revealed several roadways within the planning area will exceed capacity by the design year. Table 7 and Figure 9 present the capacity deficiencies for the design year. Complete recommendations for these facilities are included in Chapter 2 of this report.

Table 6 - 2007 Capacity Deficiencies

Roadway / Description	Deficiency
NC 14-87 From SR 1714 (Aiken Rd) to NC 700-770/SR 3003 (Meadow Rd)	Near Capacity
NC 14-87-770 From SR 1747 (Stadium Drive) to SR 2066 (Kings Highway) From SR 2066 (Kings Highway) to NC 87-770	Near Capacity Over Capacity
SR 1561 (S. Hamilton Street) From SR 1605 (S. Oakland Ave) to SR 1605 (N. Bridge Street)	Near Capacity
SR 1604 (Washington Street) From SR 2281 (Old NC 135) to SR 1561 (S. Hamilton Street) From SR 1561 (S. Hamilton Street) to SR 1605 (S. Bridge St)	Near Capacity Over Capacity
SR 1605 (S. Bridge Street) From SR 1604 (Washington Street) to SR 2066 (W. Kings Highway)	Over Capacity
SR 3003 (W. Meadow Road) From SR 3002 (Boone Road) to SR 1747 (Stadium Drive)	Near Capacity

Table 7 - 2035 Capacity Deficiencies

Roadway / Description	Deficiency
NC 87 From Virginia State Line to SR 1605 (N. Oakland Ave)	Near Capacity
NC 14-87 From SR 1605 (N. Oakland Ave) to SR 1714 (Aiken Road) From SR 1714 (Aiken Road) to NC 700-770/SR 3003 (Meadow Road)	Near Capacity Over Capacity
NC 14-87-770 From NC 700-770/SR 3003 (Meadow Road) to SR 1747 (Stadium Drive) From SR 1747 (Stadium Drive) to NC 87-770	Near Capacity Over Capacity
NC 87-770 SR 2282 (S. Hamilton Street) to NC 14	Over Capacity
NC 135 From Eden PAB to SR 2221 (Eden Road) From SR 2221 (Eden Road) to NC 770	Near Capacity Over Capacity
SR 1561 (S. Hamilton Street) From SR 1605 (S. Oakland Ave) to SR 1605 (N. Bridge Street)	Over Capacity
SR 1604 (Washington Street) From SR 2281 (Old NC 135) to SR 1605 (S. Bridge St)	Over Capacity
SR 1605 (S. Bridge Street) From SR 1604 (Washington Street) to SR 2066 (W. Kings Highway)	Over Capacity
SR 1747 (Stadium Drive) From NC 14-87-770 to New Street	Near Capacity
SR 1962 (S. Pierce Street) From SR 1747 (Stadium Drive) to SR 2066 (E. Kings Highway)	Near Capacity
SR 2066 (Kings Highway) From SR 1605 (S. Bridge Street) to SR 1962 (S. Pierce Street)	Near Capacity
SR 3003 (W. Meadow Road) From SR 3002 (Boone Road) to SR 1747 (Stadium Drive) SR 1747 (Stadium Drive) to NC 14-87-770	Over Capacity Near Capacity

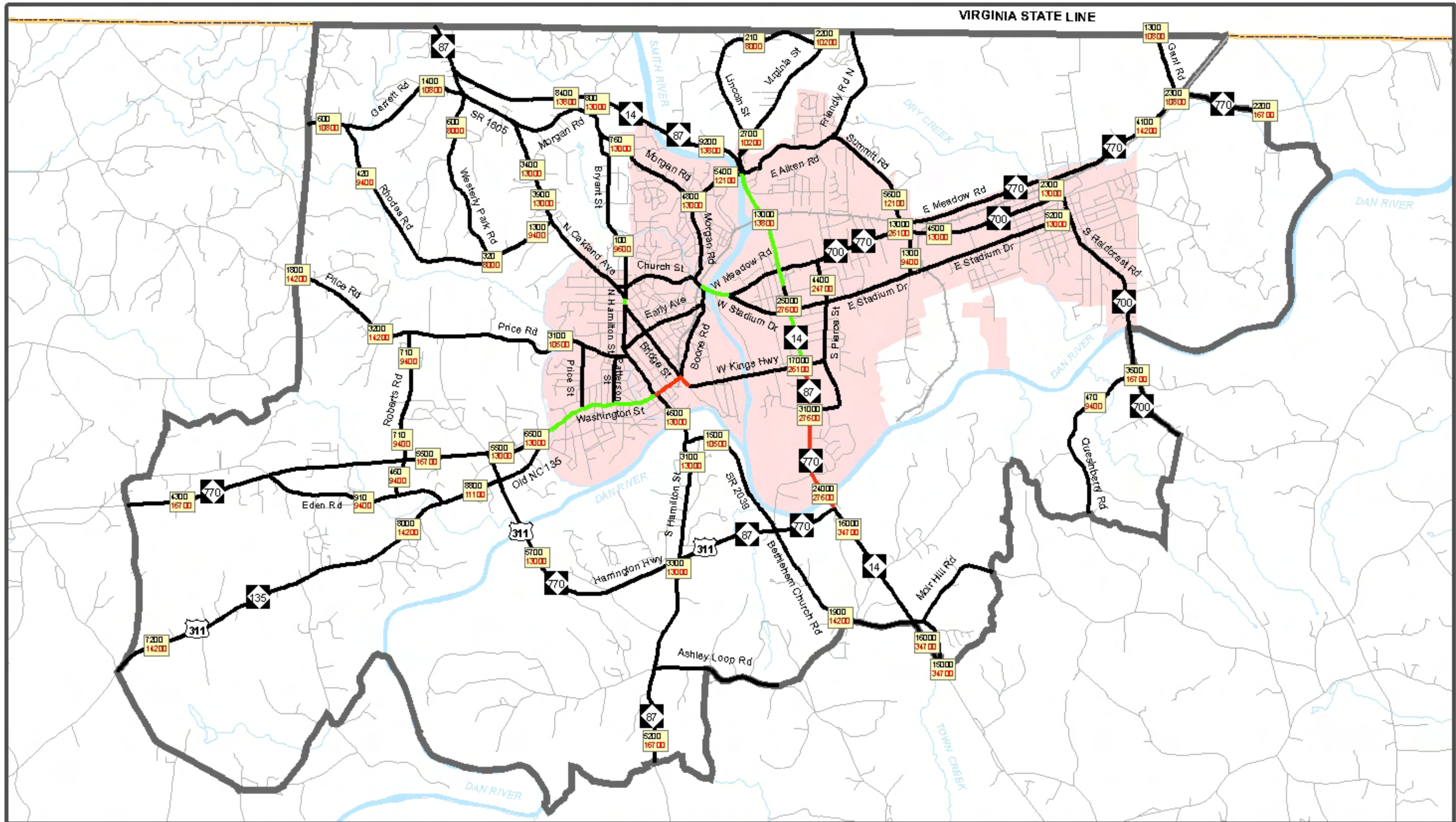

VIRGINIA STATE LINE

Base map date: September 2007

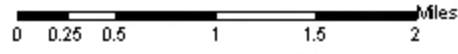
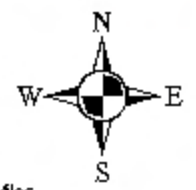

31000 2007 Traffic Volume
27600 Existing Capacity

- Near Capacity
- Over Capacity
- Network Roads

- Planning Area Boundary
- County Boundary
- City Boundary

City of Eden
Figure 8:
2007 Volumes and
Highway Deficiencies

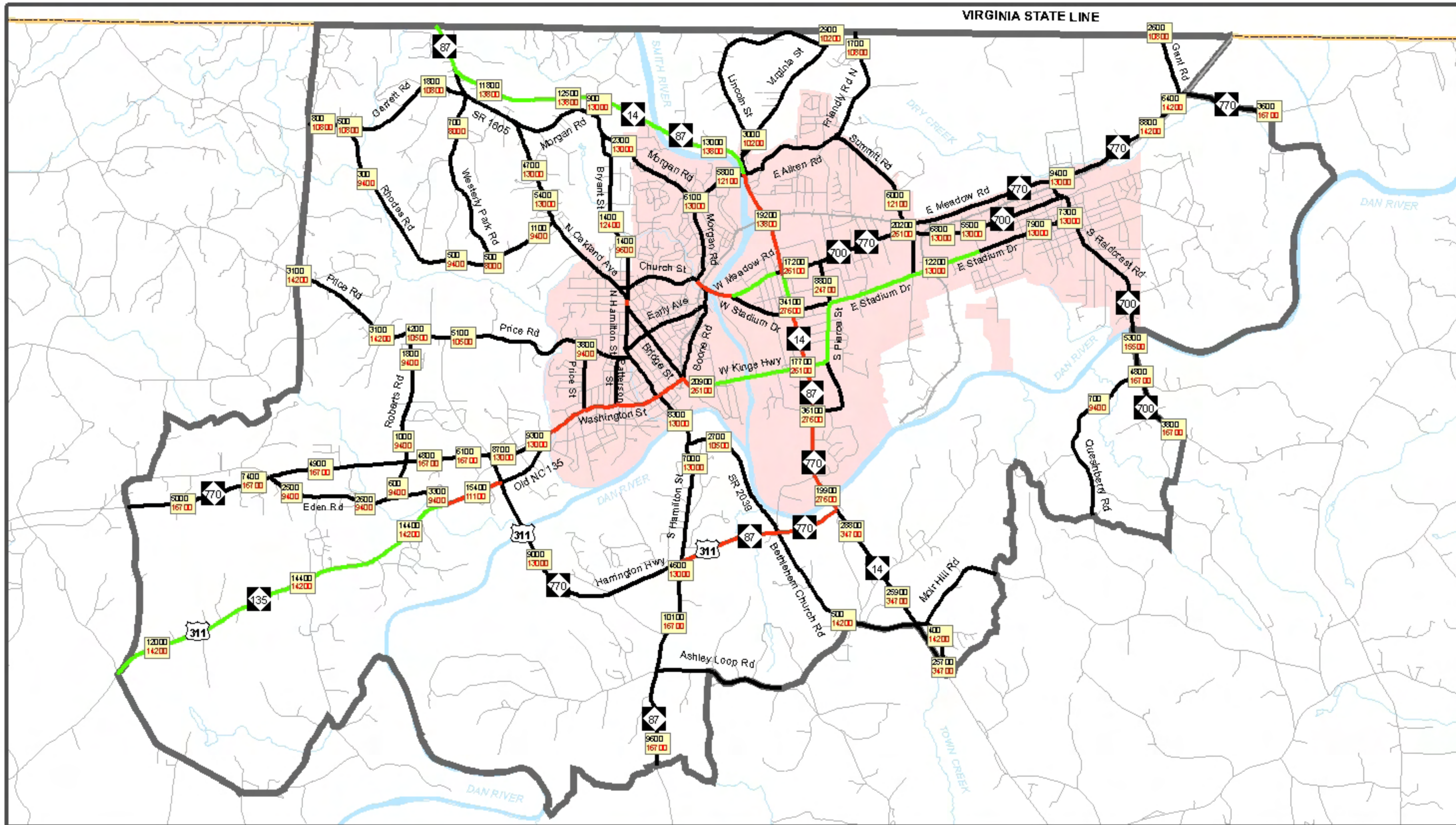

VIRGINIA STATE LINE

City of Eden
Figure 9:
2035 Volumes and
Highway Deficiencies

36100 2035 Traffic Volume
 27600 Existing Capacity

Base map date: September 2007

0 0.25 0.5 1 1.5 2 Miles

- Near Capacity
- Over Capacity
- Network Roads
- Planning Area Boundary
- County Boundary
- City Boundary

Level of Service (LOS)

The relationship of travel demand compared to the roadway capacity determines the level of service (LOS) of a roadway. Six levels of service identify the range of possible conditions. Designations range from LOS A, which represents the best operating conditions, to LOS F, which represents the worst operating conditions.

Design requirements for roadways vary according to the desired capacity and level of service. LOS D indicates “practical capacity” of a roadway, or the capacity at which the public begins to express dissatisfaction. Recommended improvements and overall design of the transportation plan were based upon achieving a minimum LOS E on existing facilities and new facilities. The six levels of service are described below and illustrated in Figure 10.

- **LOS A**: describes free-flow operations. Free-flow speeds prevail. Vehicles are almost completely unimpeded in their ability to maneuver within the traffic stream. The effects of incidents or point breakdowns are easily absorbed at this level.
- **LOS B**: represents reasonably free flow, and free-flow speeds are maintained. The ability to maneuver within the traffic stream is only slightly restricted, and the general level of physical and psychological comfort provided to drivers is still high. The effects of minor incidents and point breakdowns are still easily absorbed.
- **LOS C**: provides for flow with speeds at or near the free flow speed of the freeway. Freedom to maneuver within the traffic stream is noticeably restricted, and lane changes require more care and vigilance on the part of the driver. Minor incidents may still be absorbed, but the local deterioration in service will be substantial. Queues may be expected to form behind any significant blockage.
- **LOS D**: is the level at which speeds begin to decline slightly with increasing flows and density begins to increase somewhat more quickly. Freedom to maneuver within the traffic stream is more noticeably limited, and the driver experiences reduced physical and psychological comfort levels. Even minor incidents can be expected to create queuing, because the traffic stream has little space to absorb disruptions.
- **LOS E**: describes operation at capacity. Operations at this level are volatile, because there are virtually no usable gaps in the traffic stream. Vehicles are closely spaced, leaving little room to maneuver within the traffic stream. Any disruption of the traffic stream, such as vehicles entering from a ramp or a vehicle changing lanes, can establish a disruption wave that propagates throughout the upstream traffic flow. At capacity, the traffic stream has no ability to dissipate even the most minor disruption, and any incident can be expected to produce a serious breakdown with extensive queuing.

Maneuverability within the traffic stream is extremely limited, and the level of physical and psychological comfort afforded the driver is poor.

- LOS F:** describes breakdowns in vehicular flow; and with such stop-and-go conditions, it is difficult to predict a flow rate. These conditions generally exist within queues forming behind breakdown points. Breakdowns occur when the ratio of existing demand to actual capacity or of forecast demand to estimated capacity exceeds 1.00. The various reasons for these breakdowns (as identified in the HCM) include traffic incidents, which can cause a temporary reduction in the capacity of a short segment; and points of recurring congestion, such as merge or weaving segments and lane drops.

Figure 10 - Level of Service Illustrations

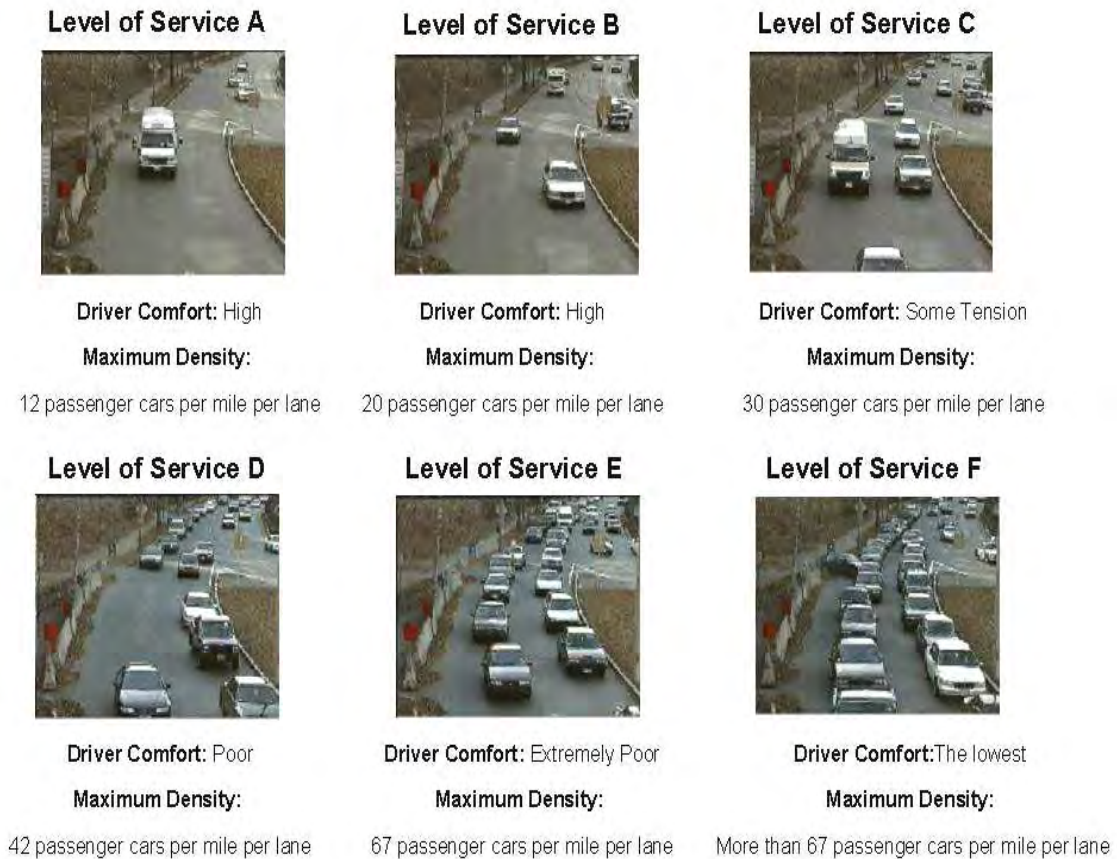

Source: 2000 Highway Capacity Manual

V. Environmental Screening

In recent years, environmental considerations associated with transportation construction have come to the forefront of the planning process. Section 102 of the National Environmental Policy Act (NEPA) requires the completion of an Environmental Impact Statement (EIS) for projects that have a significant impact on the environment. The EIS includes impacts on wetlands, wildlife, water quality, historic properties, and public lands. While this report does not cover the environmental concerns in as much detail as an EIS would, consideration for many of these factors was incorporated into the development of the Comprehensive Transportation Plan. These factors were also incorporated into the recommended improvements. Environmental features found in the City of Eden Planning Area are shown in Figures 11 and 12.

Wetlands

Wetlands are those lands where saturation with water is the dominant factor in determining the nature of soil development and the types of plant and animal communities living in the soil and on its surface. Wetlands are crucial ecosystems in our environment. They help regulate and maintain the hydrology of our rivers, lakes, and streams by storing and slowly releasing floodwaters. Wetlands help maintain the quality of water by storing nutrients, reducing sediment loads, and reducing erosion. They are also critical to fish and wildlife populations by providing an important habitat for approximately one-third of the plant and animal species that are federally listed as threatened or endangered.

The National Wetlands Inventory showed several wetlands throughout the City of Eden Planning Area. Wetland impacts have been avoided or minimized to the greatest extent possible while preserving the integrity of the transportation plan.

Threatened and Endangered Species

The Threatened and Endangered Species Act of 1973 allows the U.S. Fish and Wildlife Service to impose measures on the Department of Transportation to mitigate the environmental impacts of a transportation project on endangered plant and animal species, as well as critical wildlife habitats. Locating any rare species that exist within the City of Eden Planning Area during this early planning stage will help to avoid or minimize impacts.

A preliminary review of the Federally Listed Threatened and Endangered Species in the area was completed to determine what effects, if any, the recommended improvements may have on wildlife. Mapping from the N.C. Department of Environment and Natural Resources revealed occurrences of threatened or endangered plant and/or animal species in the area which are summarized in Table 8. No threatened or endangered species are anticipated to

be adversely impacted by any of the transportation plan recommendations. However, a detailed field investigation is recommended prior to construction of any highway project in this area.

Table 8: Threatened or Endangered Species		
Species	Common Name	Major Group
Berberis canadensis	American Barberry	Plant
Echinacea laevigata	Smooth Coneflower	Plant
Hypentelium roanokense	Roanoke Hog Sucker	Fish
Lasmigona subviridis	Green Floater	Mollusk
Lotus helleri	Carolina Birdfoot-trefoil	Plant
Scartomyzon ariommus	Bigeye Jumprock	Fish
Sedum glaucophyllum	Cliff Stonecrop	Plant
Solidago rigida ssp. glabrata	Southeastern Bold Goldenrod	Plant
Tradescantia virginiana	Virginia Spiderwort	Plant

Historic Sites

Section 106 of the National Historic Preservation Act requires the Department of Transportation to identify historic properties listed in, as well as eligible for, the National Register of Historic Places (NRHP). The NCDOT must consider the impacts of transportation projects on these properties and consult with the Federal Advisory Council on Historic Preservation. N.C. General Statute 121-12(a) requires the NCDOT to identify historic properties listed on the National Register, but not necessarily those that are eligible to be listed. The NCDOT must consider the impacts and consult with the N.C. Historical Commission, but is not bound by their recommendations.

The location of historic sites with the City of Eden Planning Area was investigated to determine any possible impacts resulting from the recommended improvements. This investigation identified the following properties listed on the NRHP: St. Luke’s Episcopal Church, Mount Sinai Baptist Church, First Baptist Church, the Dempsey-Reynolds-Taylor House, the Bullard-Ray House, the Doctor Franklin King House, the Leaksville-Spray Institute, the Cascade Plantation, and the Lower Sauratown Plantation.

None of the locations are impacted by the recommendations presented in this plan.

Archaeological Sites

The location of recorded archaeological sites was researched to determine the possible impacts of proposed roadway projects. This initial investigation identified these sites within the City of Eden Planning Area. None of these sites are expected to be impacted by the recommendations presented in this plan.

However, archaeological sites are often difficult to identify without actual field excavation. As a result, possible sites may not be identified during the initial planning process; therefore, each proposed project should be evaluated individually prior to construction.

Educational Facilities

The location of educational facilities in the City of Eden Planning Area was considered during the development of the transportation plan. No proposed facilities or improvements shall displace any school or other educational facility.

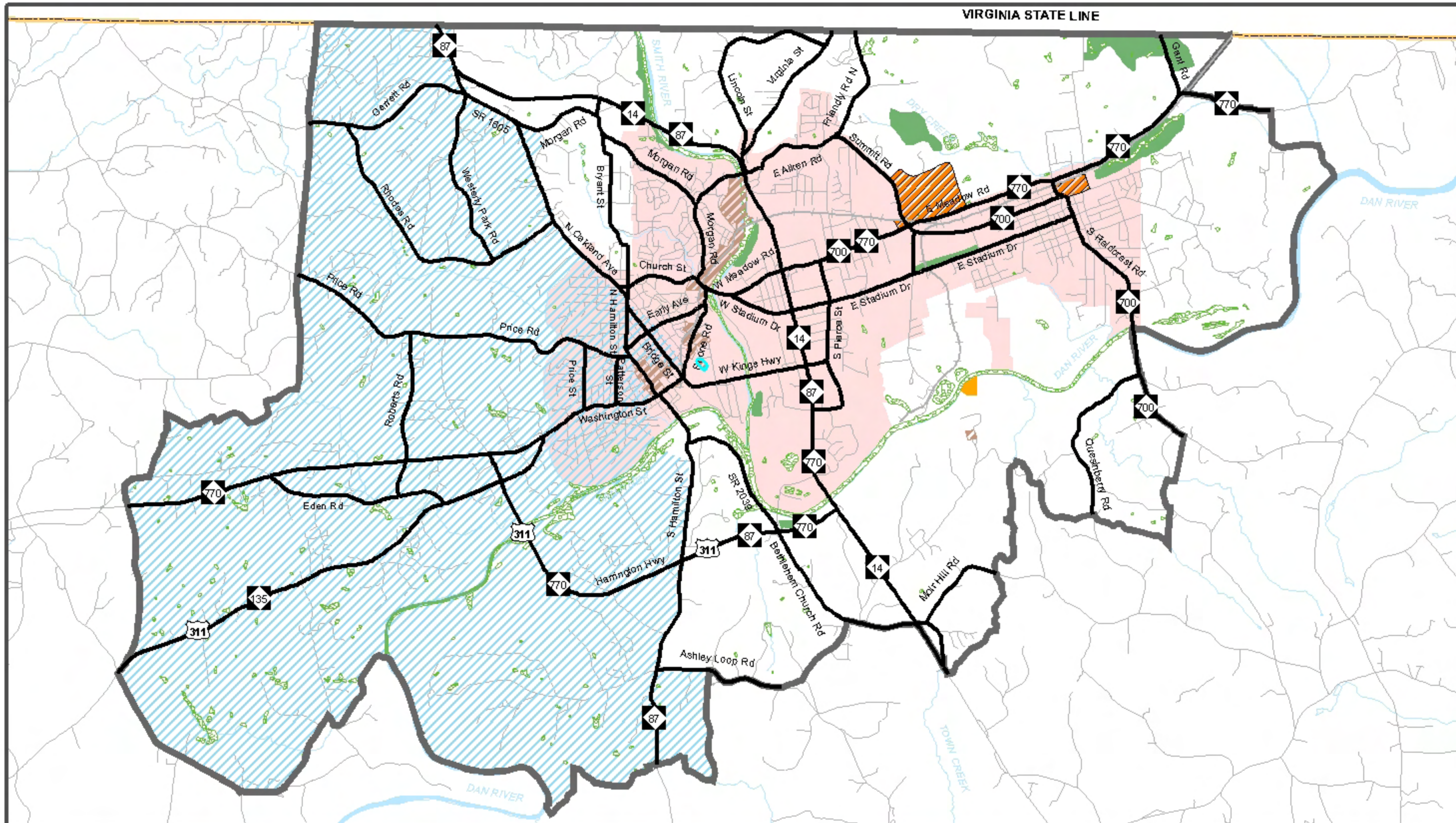

Plan date: November 18, 2008

Base map date: September 2007

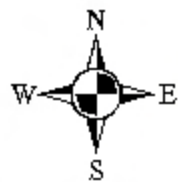

Refer to CTP document for more details

- National Historic Register Districts
- Hazardous Substance Disposal Sites
- Archaeological Sites
- National Wetland Inventory
- Significant Natural Heritage Areas
- Water Supply Water Shed
- Transportation Network
- Planning Area Boundary
- County Boundary
- City Boundary

City of Eden Figure 11:

Environmental Features I

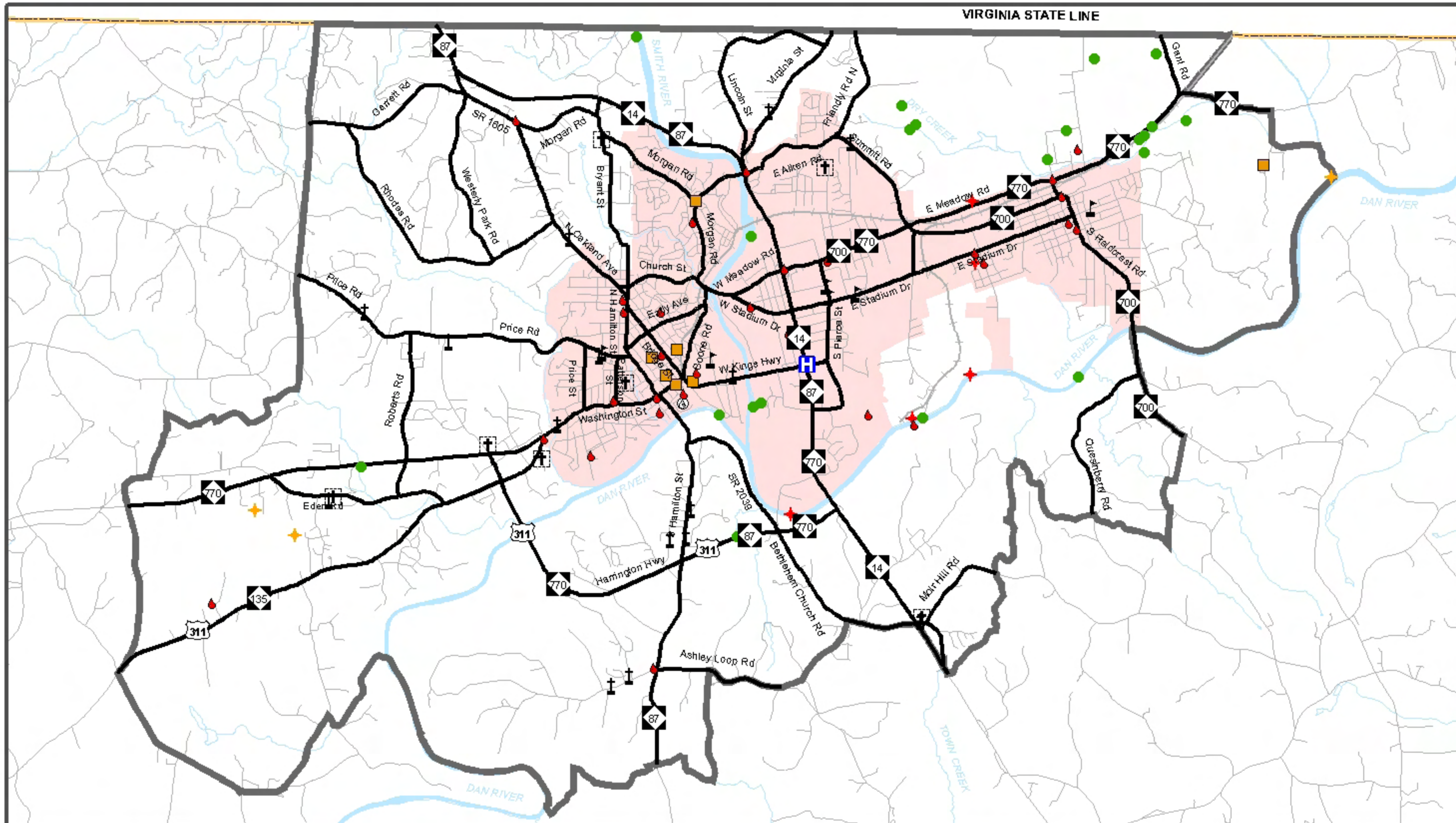

Plan date: November 18, 2008

Base map date: September 2007

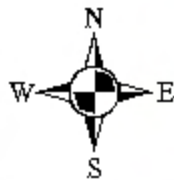

Refer to CTP document for more details

- | | | |
|---|---------------------|--------------------------|
| ▲ Groundwater Incidents Unverified | ⛪ Cemeteries | — Rivers and Streams |
| ⊕ Public Water Supply Water Sources | 🎓 Public Schools | — Transportation Network |
| ● Natural Heritage Element Occurrence | 🏥 Hospitals | ▭ Planning Area Boundary |
| 🏠 National Historic Register Structures | 📍 NPDES Major Sites | ▭ County Boundary |
| ⛪ Churches | ⊕ NPDES Minor Sites | ▭ City Boundary |

City of Eden Figure 12:

Environmental Features II

VI. Public Involvement

Since the passage of the Federal Intermodal Surface Transportation Efficiency Act of 1991 (ISTEA), the emphasis on public involvement in transportation has taken on a new role. Although public participation has been an element of long range transportation planning in the past, these regulations call for a much more proactive approach. The NCDOT's Transportation Planning Branch has a long history of making public involvement a key element in the development of any long-range transportation plan, regardless the size of the planning area. This chapter is designed to provide an overview of the public involvement elements implemented into the development of the City of Eden CTP.

The Piedmont Triad Rural Planning Organization (PTRPO) requested the development of a comprehensive transportation plan for the City of Eden through a prioritized list of regional needs. A meeting was held with the Eden City Council February of 2006 to formally initiate the study, provide an overview of the transportation planning process, and to gather input on their transportation needs.

Throughout the course of the study, the TPB met with the Eden City Planning staff, as well as other groups and individual with vested interest in the CTP, to provide plan information, to discuss population and employment projections, and to discuss the proposed recommendations.

A transportation and land use survey was conducted in late 2006 to solicit feedback from the public in regards to the future of transportation in the City of Eden. This was delivered to the citizens of Eden through their monthly utility bills as well as available at the local library and online at the City of Eden's website, the PTRPO's website, and the NCDOT – TPB's website. Almost 400 responses were received from this survey. The results of this survey are located in Appendix G.

Public Meetings and a public hearing were held in the City of Eden to solicit comments from the public as well as present the proposed Comprehensive Transportation Plan.

A meeting was held on October 19-20, 2006 at the Leaksville United Methodist Church. This was a City of Eden "Visioning Meeting" presented by the group "The Advocates for Eden." There were a total of four presentations (two on each day) conducted to interested parties in regards to transportation planning in the City of Eden. Public comments and suggestions were also taken at this time.

An informational meeting was also held on September 23, 2008 at 5:30 pm during the regularly scheduled Eden Planning Board Meeting. This gave local

officials a first glance at the proposed plan and gave them time to provide final comments before the public hearing and adoption.

A meeting was held on November 3, 2008 from 5:30-7:00 pm in the Eden City Hall. This meeting was to present the final recommendations of the CTP before the Public Hearing at the Eden City Council Meeting two weeks later.

Each of these meetings was publicized in the local newspaper, on the City of Eden's website, the Piedmont Triad RPO's website, and the NCDOT – Transportation Planning Branch's website.

A public hearing was held on November 18, 2008 during the regularly scheduled Eden City Council Meeting. The purpose of this meeting was to discuss the plan recommendations and to solicit final comments from the public. The CTP was unanimously adopted during this meeting.

The Piedmont Triad RPO voted unanimously to endorse the CTP on December 17, 2008. The North Carolina Department of Transportation voted to mutually adopt the City of Eden CTP on February 5, 2009.



***A
P
P
E
N
D
I
C
E
S***

Appendix A Resources and Contacts

North Carolina Department of Transportation

Customer Service Office
1-877-DOT4YOU
(1-877-368-4968)

Secretary of Transportation
1501 Mail Service Center
Raleigh, NC 27699-1501
(919) 733-2520

*Board of Transportation Member**

Current contact information for the Board of Transportation may be accessed from the

NCDOT homepage below or by calling the Customer Service Office.

<https://apps.dot.state.nc.us/dot/directory/authenticated/UnitPage.aspx?id=30>

*Highway Division Engineers**

Division specific contact information can be found at

<https://apps.dot.state.nc.us/dot/directory/authenticated/ToC.aspx>

Contact Whom, When?

Division Engineer

Contact the Division Engineer with general questions concerning NCDOT activities within each Division; information on Small Urban Funds.

Division Construction Engineer

Contact the Division Construction Engineer for information concerning major roadway improvements under construction.

Division Traffic Engineer

Contact the Division Traffic Engineer for information concerning high- collision locations.

District Engineer

Contact the District Engineer for information regarding Driveway Permits, Right of Way, Encroachments, and Development Reviews.

** See page A4 for Division 7 contact information.*

County Maintenance Engineer

Contact the County Maintenance Engineer regarding any maintenance activities, such as drainage.

Transportation Planning Branch (TPB)

Contact the Transportation Planning Branch with long-range planning questions.

1554 Mail Service Center

Raleigh, NC 27699-1554

(919) 733-4705

<https://apps.dot.state.nc.us/dot/directory/authenticated/UnitPage.aspx?id=3234>

Secondary Roads Office

Contact the Secondary Roads Office for information regarding the Industrial Access Funds Program.

P.O. Box 25201

Raleigh, NC 27699

(919) 733-3250

<https://apps.dot.state.nc.us/dot/directory/authenticated/UnitPage.aspx?id=135>

Program Development Branch

Contact the Program Development Branch for information concerning Roadway Official Corridor Maps and the Transportation Improvement Program (TIP).

1534 Mail Service Center

Raleigh, NC 27699-1534

(919) 733-2039

<https://apps.dot.state.nc.us/dot/directory/authenticated/UnitPage.aspx?id=632>

Project Development & Environmental Branch (PDEA)

Contact PDEA for information on environmental studies for projects that are included in the TIP.

1548 Mail Service Center

Raleigh, NC 27699-1548

(919) 733-3141

<https://apps.dot.state.nc.us/dot/directory/authenticated/UnitPage.aspx?id=3212>

Strategic Planning Office (SPOT)

Contact SPOT for information regarding the project prioritization process.

1501 Mail Service Center

Raleigh, NC 27699-1501

(919) 715-0951

<https://apps.dot.state.nc.us/dot/directory/authenticated/UnitPage.aspx?id=11054>

Highway Design Branch

Contact the Highway Design Branch for information regarding alignment for projects that are included in the TIP.

1584 Mail Service Center
Raleigh, NC 27699-1584
(919) 250-4001

<https://apps.dot.state.nc.us/dot/directory/authenticated/UnitPage.aspx?id=659>

Public Transportation Division

Contact the Public Transportation Division for information public transit systems.

1550 Mail Service Center
Raleigh, NC 27699-1550
(919) 733-4713

<https://apps.dot.state.nc.us/dot/directory/authenticated/UnitPage.aspx?id=3366>

Other NCDOT Departments

Contact information for other departments within the NCDOT not listed here are available by calling the Customer Service Office or by visiting the NCDOT homepage at

<https://apps.dot.state.nc.us/dot/directory/authenticated/ToC.aspx>

Other State Government Offices

Division of Community Assistance

Contact the Division of Community Assistance for information regarding the Community Planning Program. You may find their contact information at:

<http://www.nccommerce.com/en/CommunityServices/>

Division 7, District 3 Contacts (Rockingham County)

Board Member

Mr. J. Douglas Galyon
PO Box 14996
Greensboro, NC 27415-4996
(336) 334-3192
douggalyon@ncdot.gov

District 3 Engineer

Mr. Paul Ingram, PE
PO Box 2513
920 Montgomery St.
Reidsville, 27323-2513
(336) 634-5644
pingram@ncdot.gov

Division 7 Engineer

Mr. Mike Mills, PE
PO Box 14996
1584 Yanceyville Street
Greensboro, 27415-4996
(336) 314-3192
mmills@ncdot.gov

Division Project Manger

Mr. John Hunsinger
PO Box 14996
1584 Yanceyville Street
Greensboro, 27415-4996
(336) 314-3192
jhunsinger@ncdot.gov

Division Maintenance Engineer

Mr. Brad Wall, PE
PO Box 14996
1584 Yanceyville Street
Greensboro, 27415-4996
(336) 314-3192
bwall@ncdot.gov

Division Construction Engineer

Ms. Patty Eason, PE
PO Box 14996
1584 Yanceyville Street
Greensboro, 27415-4996
(336) 314-3192
peason@ncdot.gov

Division Traffic Engineer

Kelvin L. Jordan
PO Box 14996
1584 Yanceyville Street
Greensboro, 27415-4996
(336) 256-0551
kjordan@ncdot.gov

Secondary Roads Manager

Delbert Roddenberry, PE
1535 MAIL SERVICE CENTER (MAIL)
1 South Wilmington Street (Delivery)
Raleigh NC 27601
(919) 733-3250
droddenberry@ncdot.gov

Transportation Planning Manager

Mr. Mike Bruff, PE
1554 MAIL SERVICE CENTER (MAIL)
1 South Wilmington Street (Delivery)
Raleigh NC 27601
(919) 733-4705
mbruff@ncdot.gov

Western Planning Unit Head

Ms. Earlene Thomas, PE
1554 MAIL SERVICE CENTER (MAIL)
1 South Wilmington Street (Delivery)
Raleigh NC 27601
(919) 733-4705
ewthomas@ncdot.gov

Piedmont Triad RPO Planner

Ms. Hanna Cockburn, AICP
2216 West Meadowview Rd.
Wilmington Bldg. Suite 201
Greensboro, NC 27407-3480
(336) 294-4950
hcockburn@ptcog.org

NCDOT Piedmont Triad RPO Coordinator

Ms. Vernia Wilson
1554 MAIL SERVICE CENTER (MAIL)
1 South Wilmington Street (Delivery)
Raleigh NC 27601
(919) 733-4705
vrwilson1@ncdot.gov

Appendix B

Definitions for CTP Maps

Highway Map

- **Freeways¹**
 - Functional purpose – high mobility, high volume, high speed
 - Posted speed – 55 mph or greater
 - Cross section – minimum four lanes with continuous median
 - Multi-modal elements – High Occupancy Vehicles (HOV)/High Occupancy Transit (HOT) lanes, busways, truck lanes, park-and-ride facilities at/near interchanges, adjacent shared use paths (separate from roadway and outside ROW)
 - Type of access control – full control of access
 - Access management – interchange spacing (urban – one mile; non-urban – three miles); at interchanges on the intersecting roadway, full control of access for 1,000' or for 350' plus 650' island or median; use of frontage roads, rear service roads
 - Intersecting facilities – interchange or grade separation (no signals or at-grade intersections)
 - Driveways – not allowed

- **Expressways¹**
 - Functional purpose – high mobility, high volume, medium-high speed
 - Posted speed – 45 to 60 mph
 - Cross section – minimum four lanes with median
 - Multi-modal elements – HOV lanes, busways, very wide paved shoulders (rural), shared use paths (separate from roadway but within ROW)
 - Type of access control – limited or partial control of access;
 - Access management – minimum interchange/intersection spacing 2,000 feet; median breaks only at intersections with minor roadways or to permit U-turns; use of frontage roads, rear service roads; driveways limited in location and number; use of acceleration/deceleration or right turning lanes
 - Intersecting facilities – interchange; at-grade intersection for minor roadways; right-in/right-out and/or left-over or grade separation (no signalization for through traffic)
 - Driveways – right-in/right-out only; direct driveway access via service roads or other alternate connections

- **Boulevards**
 - Functional purpose – moderate mobility; moderate access, moderate volume, medium speed
 - Posted speed – 30 to 55 mph
 - Cross section – two or more lanes with median (median breaks allowed for U-turns per current NCDOT *Driveway Manual*)
 - Multi-modal elements – bus stops, bike lanes (urban) or wide paved shoulders (rural), sidewalks (urban - local government option)
 - Type of access control – limited control of access, partial control of access, or no control of access
 - Access management – two lane facilities may have medians with crossovers, medians with turning pockets or turning lanes; use of acceleration/deceleration or right turning

¹ Every effort will be made to ensure that all Tier 1 (Statewide importance) facilities on the NCMIN (North Carolina Multimodal Investment Network) will be Freeway or Expressway on the Comprehensive Transportation Plan

- lanes is optional; for abutting properties, use of shared driveways, internal out parcel access and cross-connectivity between adjacent properties is strongly encouraged
 - Intersecting facilities – at grade intersections and driveways; interchanges at special locations with high volumes
 - Driveways – primarily right-in/right-out, some right-in/right-out in combination with median leftovers; major driveways may be full movement when access is not possible using an alternate roadway
- Other Major Thoroughfares
 - Functional purpose – balanced mobility and access, moderate volume, low to medium speed
 - Posted speed – 25 to 55 mph
 - Cross section – four or more lanes without median
 - Multi-modal elements – bus stops, bike lanes/wide outer lane (urban) or wide paved shoulder (rural), sidewalks (urban)
 - Type of access control – no control of access
 - Access management – continuous left turn lanes; for abutting properties, use of shared driveways, internal out parcel access and cross-connectivity between adjacent properties is strongly encouraged
 - Intersecting facilities – intersections and driveways
 - Driveways – full movement on two lane roadway with center turn lane as permitted by the current NCDOT *Driveway Manual*
 - Minor Thoroughfares
 - Functional purpose – balanced mobility and access, moderate volume, low to medium speed
 - Posted speed – 25 to 45 mph
 - Cross section – ultimately three lanes (no more than one lane per direction) or less without median
 - Multi-modal elements – bus stops, bike lanes/wide outer lane (urban) or wide paved shoulder (rural), sidewalks (urban)
 - ROW – no control of access
 - Access management – continuous left turn lanes; for abutting properties, use of shared driveways, internal out parcel access and cross-connectivity between adjacent properties is strongly encouraged
 - Intersecting facilities – intersections and driveways
 - Driveways – full movement on two lane with center turn lane as permitted by the current NCDOT *Driveway Manual*
 - Existing – Roadway facilities that are not recommended to be improved.
 - Needs Improvement – Roadway facilities that need to be improved for capacity, safety, or system continuity. The improvement to the facility may be widening, other operational strategies, increasing the level of access control along the facility, or a combination of improvements and strategies. **“Needs improvement” does not refer to the maintenance needs of existing facilities.**
 - Recommended – Roadway facilities on new location that are needed in the future.
 - Interchange – Through movement on intersecting roads is separated by a structure. Turning movement area accommodated by on/off ramps and loops.
 - Grade Separation – Through movement on intersecting roads is separated by a structure. There is no direct access between the facilities.
 - Full Control of Access – Connections to a facility provided only via ramps at interchanges. No private driveway connections allowed.

- ❑ Limited Control of Access – Connections to a facility provided only via ramps at interchanges (major crossings) and at-grade intersections (minor crossings and service roads). No private driveway connections allowed.
- ❑ Partial Control of Access – Connections to a facility provided via ramps at interchanges, at-grade intersections, and private driveways. Private driveway connections shall be defined as a maximum of one connection per parcel. One connection is defined as one ingress and one egress point. These may be combined to form a two-way driveway (most common) or separated to allow for better traffic flow through the parcel. The use of shared or consolidated connections is highly encouraged.
- ❑ No Control of Access – Connections to a facility provided via ramps at interchanges, at-grade intersections, and private driveways.

Public Transportation and Rail Map

- ❑ Bus Routes – The primary fixed route bus system for the area. Does not include demand response systems.
- ❑ Fixed Guideway – Any transit service that uses exclusive or controlled rights-of-way or rails, entirely or in part. The term includes heavy rail, commuter rail, light rail, monorail, trolleybus, aerial tramway, included plane, cable car, automated guideway transit, and ferryboats.
- ❑ Operational Strategies – Plans geared toward the non-single occupant vehicle. This includes but is not limited to HOV lanes or express bus service.
- ❑ Rail Corridor – Locations of railroad tracks that are either active or inactive tracks. These tracks were used for either freight or passenger service.
 - Active – rail service is currently provided in the corridor; may include freight and/or passenger service
 - Inactive – right of way exists; however, there is no service currently provided; tracks may or may not exist
 - Recommended – It is desirable for future rail to be considered to serve an area.
- ❑ High Speed Rail Corridor – Corridor designated by the U.S. Department of Transportation as a potential high speed rail corridor.
 - Existing – Corridor where high speed rail service is provided (there are currently no existing high speed corridor in North Carolina).
 - Recommended – Proposed corridor for high speed rail service.
- ❑ Rail Stop – A railroad station or stop along the railroad tracks.
- ❑ Intermodal Connector – A location where more than one mode of public transportation meet such as where light rail and a bus route come together in one location or a bus station.
- ❑ Park and Ride Lot – A strategically located parking lot that is free of charge to anyone who parks a vehicle and commutes by transit or in a carpool.

Bicycle Map

- ❑ On Road-Existing – Conditions for bicycling on the highway facility are adequate to safely accommodate cyclists.
- ❑ On Road-Needs Improvement – At the systems level, it is desirable for the highway facility to accommodate bicycle transportation; however, highway improvements are necessary to create safe travel conditions for the cyclists.
- ❑ On Road-Recommended – At the systems level, it is desirable for a recommended highway facility to accommodate bicycle transportation. The highway should be designed and built to safely accommodate cyclists.
- ❑ Off Road-Existing – A facility that accommodates bicycle transportation (may also accommodate pedestrians, eg. greenways) and is physically separated from a highway facility usually on a separate right-of-way.
- ❑ Off Road-Needs Improvement – A facility that accommodates bicycle transportation (may also accommodate pedestrians, eg. greenways) and is physically separated from a highway facility usually on a separate right-of-way that will not adequately serve future bicycle needs.

- Improvements may include but are not limited to: widening, paving (not re-paving), improved horizontal or vertical alignment.
- Off Road-Recommended – A facility needed to accommodate bicycle transportation (may also accommodate pedestrians, eg. greenways) and is physically separated from a highway facility usually on a separate right-of-way. This may also include greenway segments that do not necessarily serve a transportation function but intersect recommended facilities on the highway map or public transportation and rail map.

Pedestrian Map

Format for the pedestrian map is under development.

Appendix C

Street Tabulation and Recommendations

This appendix includes a detailed tabulation of all streets identified as elements of the City of Eden Comprehensive Transportation Plan. The table includes a description of the roads by sections, as well as the length, cross section, and right-of-way for each section. Also included are the existing and projected average daily traffic volumes, roadway capacity, and the recommended ultimate lane configuration. Due to space constraints, these recommended cross sections are given in the form of an alphabetic code. A detailed description of each of these codes and an illustrative figure for each can be found in Appendix D.

APPENDIX C: Street Tabulation and Recommendations

FACILITY & SECTION	2007 CONDITIONS						2035 CONDITIONS							
	DIST. MI.	RDWY. FT.	ROW FT.	NUMBER OF LANES	SPEED LIMIT (MPH)	CURRENT CAPACITY LOS E (VPD)	2007 AADT (VPD)	RDWY. FT.	ROW FT.	NUMBER OF LANES	SPEED LIMIT (MPH)	PROPOSED CAPACITY LOS E (VPD)	2035 AADT (VPD)	REC. CROSS SECTION
NC 14-87 Bypass (New Routing)														
NC 14-87 to SR 1605	0.31	24	0	2	45	13000	2700	24	0	2	45	13000	6400	ADQ
SR 1605 to SR 1557	0.70	18	0	2	45	8000	2700	24	0	2	55	13000	7100	K
SR 1557 to SR 1553	1.01	N/A						24		2	55	13000	6400	K
SR 1553 to NC 770	0.78	N/A						24		2	55	13000	8100	K
NC 770 to NC 135	0.30	24	250	2	45	13000	2700	32	250	2	45	13000	9400	B4
NC 135 to SR 2282	2.22	24	250	2	55	13000	5700	32	250	2	55	13000	8500	B4
SR 2282 to SR 2039	1.03	24	100	2	55	13000	8100	32	100	2	55	13000	10400	B4
SR 2039 to NC 14	0.65	24	100	2	55	13000	7700	24	100	2	55	13000	9600	ADQ
Harrington Hwy. East Ext. (New Routing)														
NC 14 to West Drapher Spur	1.74	N/A						24		2	55	13000	8400	K
West Drapher Spur to SR 1951	0.99	N/A						24		2	55	13000	6100	K
SR 1951 to NC 700	1.07	20	60	2	55	9400	470	24	60	2	55	13000	4800	K
West Drapher Spur (New Routing)														
NC 700 to SR 1747	0.36	N/A						24		2	35	13000	5300	K
SR 1747 to Proposed Harrington Hwy East Ext.	1.73	N/A						24		2	55	13000	8500	K
E. Aiken Rd. Realignment (New Routing)														
SR 1714 to SR 1714	0.64	N/A						22		2	35	12100	5100	K
Bryant St. Realignment (New Routing)														
SR 1708 to SR 1709	0.18	N/A						24		2	35	12400	800	K
NC 14														
Eden PAB to NC 87-770	2.00	60	150	4	55	34700	17100	64	150	4	55	43600	26700	E
NC 14-87-770														
NC 87-770 to SR 2066	1.52	60	150	5	45	27600	31700	64	150	4	45	35500	31500	E
SR 2066 to SR 1747	0.57	60	150	5	45	27600	25200	64	150	4	45	35500	31600	E
SR 1747 to NC 770	0.42	60	150	5	45	27600	19000	64	150	4	45	35500	25800	E
NC 14-87														
NC 770 to SR 1714	1.06	24	100	2	50	13800	13000	64	150	4	50	35500	25900	E
SR 1714 to SR 1700	1.50	24	150	2	55	13800	9200	64	150	4	55	35500	18400	B1
SR 1700 to SR 1605	1.56	24	150	2	55	13800	8900	64	150	4	55	35500	15700	E

APPENDIX C: Street Tabulation and Recommendations

FACILITY & SECTION	2007 CONDITIONS										2035 CONDITIONS									
	DIST. MI.		RDWY. FT.	ROW FT.	NUMBER OF LANES	SPEED LIMIT (MPH)	CURRENT LOS E (VPD)	CURRENT CAPACITY	2007 AADT (VPD)	RDWY. FT.	ROW FT.	NUMBER OF LANES	SPEED LIMIT (MPH)	PROPOSED LOS E (VPD)	PROPOSED CAPACITY	2035 AADT (VPD)	REC. CROSS SECTION			
NC 87 (North)																				
SR 1605 to Eden PAB (Virginia State Line)	0.45		24	60	2	55	17400	11000					64	150	4	55	43600	16800	E	
NC 87 (South)																				
NC 770 to SR 2105	1.16		24	100	2	45	16700	6200					24	100	2	45	16700	10100	ADQ	
SR 2105 to SR 2203	0.37		24	100	2	45	16700	5900					32	100	2	45	16700	9800	B4	
SR 2203 to Eden PAB	0.97		24	100	2	45	16700	5500					24	100	2	45	16700	9600	ADQ	
NC 135																				
Eden PAB to SR 2221	3.78		20	60	2	55	14200	7200					24	60	2	55	16700	14400	K	
SR 2221 to NC 770	0.62		20	60	2	55	11100	8800					24	60	2	55	16700	15000	K	
NC 700-770																				
NC 14-87 to SR 1962	0.39		55	70	5	35	26100	13000					55	70	5	35	26100	13500	ADQ	
SR 1962 to SR 1714	0.97		55	70	5	35	26100	13000					68	70	5	35	26100	14400	B2	
NC 700																				
SR 1714 to N. Edgewood Road	0.08		24	60	2	35	13000	4700					32	60	2	35	13000	8900	B4	
N. Edgewood Road to West Drapher Spur	0.12		24	60	2	35	13000	N/A					32	60	2	35	13000	9000	B4	
West Drapher Spur to Front Street	0.66		24	60	2	35	13000	N/A					32	60	2	35	13000	3900	ADQ	
Front Street to Main Street	1.53		24	60	2	35	13000	4500					24	60	2	35	13000	3100	B4	
Main Street to SR 1747	0.22		24	60	2	20	13000	4000					32	60	2	20	13000	2700	B4	
Main Street to SR 1951	1.62		24	60	2	35	13000	5300					32	60	2	35	13000	3700	B4	
NC 700																				
SR 1951 to Eden PAB	0.79		24	60	2	55	16700	3500					32	60	2	55	16700	3800	B4	
NC 770 (West)																				
Eden PAB to SR 2221	1.48		24	150	2	45	16700	4300					24	150	2	45	16700	7300	ADQ	
SR 2221 to SR 1530	1.37		24	150	2	45	16700	5100					24	150	2	45	16700	5900	ADQ	
SR 1530 to SR 1604	0.83		24	150	2	45	16700	5500					24	150	2	45	16700	7100	ADQ	
NC 770 (East)																				
SR 1714 to North Hale Street	1.00		60	80	5	35	26100	6600					60	80	5	55	26100	10900	ADQ	
North Hale Street to SR 1737	0.55		24	50	2	35	13000	5400					24	50	2	35	13000	8300	ADQ	
SR 1737 to Eden City Limits	0.22		20	60	2	35	13000	5300					32	60	2	35	13000	8900	B4	

APPENDIX C: Street Tabulation and Recommendations

FACILITY & SECTION	2007 CONDITIONS										2035 CONDITIONS									
	DIST. MI.	RDWY. FT.		NUMBER OF LANES	SPEED LIMIT (MPH)	CURRENT LOS E (VPD)	CURRENT CAPACITY	2007 AADT (VPD)	ROW		NUMBER OF LANES	SPEED LIMIT (MPH)	PROPOSED LOS E (VPD)	PROPOSED CAPACITY	2035 AADT (VPD)	REC. CROSS SECTION				
		FT.							2007 AADT (VPD)	2035 AADT (VPD)										
		FT.	FT.																	
NC 770 (East)																				
Eden City Limits to SR 1743	1.34	20	60	2	55	14200	4300							8800	B4					
SR 1743 to Eden PAB	0.96	24	60	2	55	14200	2400							3600	K					
SR 1501 - Garrett Road																				
Eden PAB to SR 1605	1.77	22	0	2	45	10800	1400							800	B4					
SR 1530 - Roberts Road																				
SR 1535 to NC 770	1.32	20	0	2	35	9400	710							1000	ADQ					
NC 770 to SR 2221	0.37	20	0	2	35	9400	460							300	ADQ					
SR 1535 - Price Road																				
Eden PAB to SR 1533	2.19	20	0	2	55	14200	3200							4800	B4					
SR 1533 to Eden City Limits	0.71	20	0	2	55	10500	3200							4600	B4					
SR 1535 - Center Church Road																				
Eden City Limits to SR 1561	0.82	24	0	2	35	12400	7300							9800	B4					
SR 1553 - Rhodes Road																				
SR 1501 to SR 1557	2.32	18	0	2	55	8000	420							600	K					
SR 1557 to SR 1605	0.73	18	0	2	35	8000	1300							1400	K					
SR 1557 - Westerly Park Road																				
Proposed NC 14-87 Bypass to SR 1553	1.15	18	0	2	45	8000	610							100	ADQ					
SR 1561 - S. Hamilton Street																				
SR 1605 to Early Ave	0.48	22	0	2	35	12100	7500							4100	ADQ					
Early Ave to SR 1535	0.08	22	0	2	35	12100	11000							10200	B4					
SR 1535 to SR 1604	0.48	22	0	2	35	12100	2800							4500	B4					
SR 1604 - Washington Street																				
NC 770 to SR 2281	0.59	24	150	2	45	13000	4900							8500	ADQ					
SR 2281 to SR 1561	1.27	44	60	2	35	13000	12000							13000	B4					
SR 1561 to SR 2282	0.03	45	60	2	20	13000	12000							13000	B4					
SR 1561 to SR 1605	0.29	45	60	2	20	13000	13000							13000	B4					

APPENDIX C: Street Tabulation and Recommendations

FACILITY & SECTION	2007 CONDITIONS										2035 CONDITIONS									
	DIST. MI.		RDWY. FT.	ROW FT.	NUMBER OF LANES	SPEED LIMIT (MPH)	CURRENT LOS E (VPD)	CURRENT CAPACITY	2007 AADT (VPD)	RDWY. FT.	ROW FT.	NUMBER OF LANES	SPEED LIMIT (MPH)	PROPOSED LOS E (VPD)	PROPOSED CAPACITY	2035 AADT (VPD)	REC. CROSS SECTION			
SR 1605 - N. Oakland Avenue/Bridge Street	0.55	24	0	2	45	13000	2700		24	0	2	45	13000	1600	ADQ					
NC 14-87 Bypass to SR 3004	1.10	24	0	2	45	13000	3900		24	0	2	45	13000	1400	ADQ					
SR 3004 to SR 1553	1.10	24	0	2	35	13000	8300		24	0	2	35	13000	5800	ADQ					
SR 1553 to SR 1709	0.06	24	0	2	35	13000	12000		24	0	2	35	13000	7300	ADQ					
SR 1709 to SR 1561	0.91	24	0	2	35	13000	6800		24	0	2	35	13000	9100	ADQ					
SR 1561 to SR 1604																				
SR 1700 - Fisher Hill Road	0.18	24	0	2	45	13000	720		32	0	2	45	13000	2100	B4					
NC 14-87 to SR 3004																				
SR 1708 - Bryant Street	1.02	24	0	2	35	12400	500		32	0	2	35	12400	800	B4					
SR 3004 to SR 1710																				
SR 1709 - N. Hamilton Street	0.46	24	0	2	35	12200	720		24	0	2	35	12200	4800	ADQ					
SR 1709 to SR 1605																				
SR 1714 - W. Aiken Road	0.62	22	0	2	35	12100	5400		30	0	2	35	12100	6200	B4					
SR 3004 to NC 14-87																				
SR 1714 - E. Aiken Road	0.18	22	0	2	35	12100	9000		30	0	2	35	12100	11100	B4					
NC 14-87 to SR 1716	0.87	22	0	2	35	12100	4200		30	0	2	35	12100	6300	B4					
SR 1716 to Proposed Realignment	0.43	22	0	2	35	12100	N/A		30	0	2	35	12100	5100	B4					
Proposed Realignment to SR 1797																				
SR 1714 - Summit Road	1.23	22	0	2	35	12100	5600		22	0	2	35	12100	5100	ADQ					
SR 1797 to NC 700-770																				
SR 1716 - Virginia Street	0.18	24	0	2	35	13000	4200		24	0	2	35	13000	5300	ADQ					
SR 1714 to SR 1719	1.41	18	0	2	35	10200	2700		24	0	2	35	13000	4400	K					
SR 1719 to SR 1719	0.17	18	0	2	45	10200	2200		24	0	2	45	13000	2900	K					
SR 1719 to Eden PAB (Virginia State Line)																				
SR 1719 - Lincoln Street	2.23	18	0	2	45	8000	210		18	0	2	45	8000	1000	ADQ					
SR 1716 to SR 1716																				
SR 1743 - Gant Road	0.64	22	0	2	45	10800	2300		30	0	2	45	10800	3400	B4					
NC 770 to Eden PAB (Virginia State Line)																				

APPENDIX C: Street Tabulation and Recommendations

FACILITY & SECTION	2007 CONDITIONS						2035 CONDITIONS									
	DIST. MI.	RDWY. FT.	ROW FT.	NUMBER OF LANES	SPEED LIMIT (MPH)	CURRENT LOS E (VPD)	CURRENT AADT (VPD)	2007 AADT (VPD)	RDWY. FT.	ROW FT.	NUMBER OF LANES	SPEED LIMIT (MPH)	PROPOSED LOS E (VPD)	PROPOSED AADT (VPD)	2035 AADT (VPD)	REC. CROSS SECTION
SR 1747 - W. Stadium Drive																
SR 3003 to NC 14-87-770	0.65	48	0	4	35	26100	6500		48	0	2	35	26100	9900		ADQ
SR 1747 - E. Stadium Drive																
NC 14-87-770 to SR 1962	0.57	48	0	4	35	26100	7600		56	0	4	35	26100	9000		B2
SR 1962 to Edgewood Road	0.71	24	0	2	35	13000	8900		32	0	2	35	13000	11300		B4
Edgewood Road to Proposed W Drapher Spur	0.29	24	60	2	35	13000			24	60	2	35	13000	8400		ADQ
West Drapher Spur to NC 700	1.42	24	60	2	35	13000	5200		24	60	2	35	13000	5900		ADQ
SR 1785 - Church Street																
SR 1605 to SR 1709	0.09	20	0	2	35	11100	7200		22	0	2	35	12100	11200		K
SR 1709 to SR 3003	0.75	20	0	2	35	11100	2500		22	0	2	35	12100	3400		K
SR 1797 - N. Friendly Road																
SR 1714 to Eden PAB (Virginia State Line)	1.20	22	0	2	55	10800	2700		30	0	2	55	10800	3300		ADQ
SR 1945 - Moir Hill Road																
SR 2039 to Eden PAB	0.99	22	60	2	55	10800	1100		30	60	2	55	10800	1800		B4
SR 1951 - Quesinberry Road																
Eden PAB to Proposed Harrington Hwy. Ext.	0.75	20	60	2	55	9400	470		24	60	2	55	13000	1500		ADQ
SR 1962 - N. Pierce Street																
NC 700-770 to SR 1747	0.43	52	60	4	35	24700	4400		60	60	4	35	24700	5100		B4
SR 1962 - S. Pierce Street																
SR 1747 to SR 2066	0.60	36	0	3	35	12400	9600		44	0	3	35	12400	8100		B4
SR 2039 - Bethlehem Church Road																
SR 2282 to NC 87-770	1.45	20	60	2	55	10500	1500		30	60	2	55	11500	2900		B4
NC 87-770 to NC 14	2.48	20	60	2	55	14200	1900		30	60	2	55	15500	3000		B4
SR 2066 - S. Bridge Street																
SR 1604 to SR 2066	0.12	36	60	3	35	13000	13000		48	60	4	35	26100	21800		G
SR 2066 - W. Kings Highway																
SR 2066 to NC 14-87-770	0.92	60	120	5	35	26100	17000		68	120	5	35	26100	25800		B1

APPENDIX C: Street Tabulation and Recommendations

FACILITY & SECTION	2007 CONDITIONS										2035 CONDITIONS									
	DIST. MI.		RDWY. FT.	ROW FT.	NUMBER OF LANES	SPEED LIMIT (MPH)	CURRENT LOS E (VPD)	CURRENT CAPACITY	2007 AADT (VPD)	RDWY. FT.	ROW FT.	NUMBER OF LANES	SPEED LIMIT (MPH)	PROPOSED LOS E (VPD)	PROPOSED CAPACITY	2035 AADT (VPD)	REC. CROSS SECTION			
SR 2066 - E. Kings Highway	0.27	60	120	5	35	24700	9600		68	120	5	35	24700	17000		B2				
NC 14-87-770 to SR 1962																				
SR 2203 - Ashley Loop Road	1.34	22	0	2	55	9400	1000		30	0	2	55	9400	1500		B4				
NC 87 to Eden PAB																				
SR 2221 - Eden Road	1.88	20	0	2	45	9400	910		20	0	2	45	9400	2100		ADQ				
NC 770 to NC 135																				
SR 2281 - Old NC 135	0.67	20	150	2	35	11100	6100		24	150	2	35	13000	4900		K				
NC 770 to SR 1604																				
SR 2282 - S. Hamilton Street	0.59	24	50	2	35	13000	4600		32	50	2	35	13000	6800		B4				
SR 1604 to SR 2039																				
SR 2039 to NC 770	1.21	24	100	2	45	13000	3300		24	100	2	45	13000	5700		ADQ				
SR 3002 - Boone Road	0.98	24	60	2	35	13000	8800		32	60	2	35	13000	9800		B4				
SR 1605 to SR 3003																				
SR 3003 - Church Street	0.08	24	60	2	35	13000	8900		32	60	2	35	13000	11900		B4				
SR 3004 to SR 3002																				
SR 3003 - W. Meadow Road	0.56	22	60	2	45	12100	11900		22	60	2	45	26100	20700		E				
SR 3002 to SR 1747																				
SR 1747 to NC 14-87	0.56	22	60	2	45	12100	7300		22	60	2	45	12100	8700		ADQ				
SR 3004 - Morgan Road	0.96	24	60	2	45	13000	550		32	60	2	45	13000	2200		B4				
SR 1605 to SR 1700																				
SR 1700 to SR 1708	0.18	24	60	2	45	13000	1000		32	60	2	45	13000	700		B4				
SR 1708 to SR 1714	1.24	24	60	2	45	13000	760		32	60	2	45	13000	2900		B4				
SR 1714 to SR 3003	0.77	24	60	2	35	13000	4800		32	60	2	35	13000	5000		B4				
Early Avenue	0.66	24	0	2	25	12400	3200		32	0	2	25	12400	6200		B4				
SR 1561 to SR 1605																				
SR 1605 to Greenwood Street	0.26	24	0	2	25	12400	3200		32	0	2	25	12400	6200		B4				
Greenwood Street to SR 3002	0.40	24	0	2	25	12400	3200		24	0	2	25	12400	6200		ADQ				

APPENDIX C: Street Tabulation and Recommendations

FACILITY & SECTION	2007 CONDITIONS							2035 CONDITIONS							REC. CROSS SECTION	
	DIST. MI.	RDWY. FT.	ROW FT.	NUMBER OF LANES	SPEED LIMIT (MPH)	CURRENT LOS E (VPD)	CURRENT AADT (VPD)	2007 AADT (VPD)	RDWY. FT.	ROW FT.	NUMBER OF LANES	SPEED LIMIT (MPH)	PROPOSED LOS E (VPD)	PROPOSED CAPACITY		2035 AADT (VPD)
E. Harris Place																
NC 14-87-770 to Morehead Ext	0.30	48	0	4	25	26100	6000		48	0	4	25	26100	9800	ADQ	
N. Edgewood Road																
NC 700 to SR 1747	0.71	20	0	2	35	11100	1300		28	0	2	35	11100	400	B4	
Main Street																
NC 770 to NC 700	0.22	24	200	2	20	13000	2200		32	0	2	20	13000	1200	B4	
Price Street																
SR 1535 to SR 1604	0.64	20	0	2	35	9400	1300		20	0	2	35	9400	3300	ADQ	
Patterson Street																
SR 1535 to SR 1604	0.48	20	0	2	35	9400	4400		20	0	2	35	9400	3000	ADQ	
Morehead Extension																
SR 2066 to E Harris Pl	0.32	24	0	2	25	12200	N/A		24	0	4	25	12200	5000	ADQ	

Appendix D

Typical Transportation Cross-Sections

Cross section requirements for roadways vary according to the capacity and level of service to be provided. Universal standards in the design of roadways are not practical. Each roadway section must be individually analyzed and its cross section determined based on the volume and type of projected traffic, existing capacity, desired level of service, and available right-of-way. These cross sections are typical for facilities on new location and where right-of-way constraints are not critical. For widening projects and urban projects with limited right-of-way, special cross sections should be developed that meet the needs of the project.

On all existing and proposed roadways delineated on the CTP, adequate right-of-way should be protected or acquired for the recommended cross sections. In addition to cross section and right-of-way recommendations for improvements, Appendix C may recommend ultimate needed right-of-way for the following situations:

- roadways which may require widening after the current planning period,
- roadways which are borderline adequate and accelerated traffic growth could render them deficient, and
- roadways where an urban curb and gutter cross section may be locally desirable because of urban development or redevelopment.

Recommended design standards relating to grades, sight distances, degree of curve, superelevation, and other considerations for roadways are given in Appendix E. The typical cross sections are described below.

A: Four Lanes Divided with Median - Freeway

Cross section "A" is typical for four-lane divided highways in rural areas that may have only partial or no control of access. The minimum median width for this cross section is 46 feet, but a wider median is desirable.

B: Seven Lanes - Curb & Gutter

Cross section "B" is typically not recommended for new projects. When the conditions warrant six lanes, cross section "D" should be recommended. Cross section "B" should be used only in special situations such as when widening from a five-lane section where right-of-way is limited. Even in these situations, consideration should be given to converting the center turn lane to a median so that cross section "D" is the final cross section.

C: Five Lanes - Curb & Gutter

Typical for major thoroughfares, cross section "C" is desirable where frequent left turns are anticipated as a result of abutting development or frequent street intersections.

D: Six Lanes Divided with Raised Median - Curb & Gutter**E: Four Lanes Divided with Raised Median - Curb and Gutter**

Cross sections "D" and "E" are typically used on major thoroughfares where left turns and intersection streets are not as frequent. Left turns would be restricted to a few selected intersections. The 16-ft median is the minimum recommended for an urban boulevard-type cross section. In most instances, monolithic construction should be utilized due to greater cost effectiveness, ease and speed of placement, and reduced future maintenance requirements. In certain cases, grass or landscaped medians result in greatly increased maintenance costs and an increase danger to maintenance personnel. Non-monolithic medians should only be recommended when the above concerns are addressed.

F: Four Lanes Divided - Boulevard, Grass Median

Cross section "F" is typically recommended for urban boulevards or parkways to enhance the urban environment and to improve the compatibility of major thoroughfares with residential areas. A minimum median width of 24 ft is recommended, with 30 ft being desirable.

G: Four Lanes - Curb and Gutter

Cross section "G" is recommended for major thoroughfares where projected travel indicates a need for four travel lanes but traffic is not excessively high, left turning movements are light, and right-of-way is restricted. An additional left turn lane would likely be required at major intersections. This cross section should be used only if the above criteria are met. If right-of-way is not restricted, future strip development could take place and the inner lanes could become de facto left turn lanes.

H: Three Lanes - Curb and Gutter

In urban environments, thoroughfares that are proposed to function as one-way traffic carriers would typically require cross section "H".

I: Two Lanes – Curb and Gutter, Parking both sides**J: Two Lanes – Curb and Gutter, Parking one side**

Cross section "I" and "J" are usually recommended for urban minor thoroughfares since these facilities usually serve both land service and traffic service functions. Cross-section "I" would be used on those minor thoroughfares where parking on both sides is needed as a result of more intense development.

K: Two Lanes - Paved Shoulder

Cross section "K" is used in rural areas or for staged construction of a wider multilane cross section. On some thoroughfares, projected traffic volumes may indicate that two travel lanes will adequately serve travel for a considerable period of time. For areas that are growing and future widening will be necessary, the full right-of-way of 100 ft should be required. In some instances, local ordinances may not allow the full 100-ft. In those cases, 70 ft should be preserved with the understanding that the full 70-ft will be preserved by use of building setbacks and future street line ordinances.

L: Six Lanes Divided with Grass Median - Freeway

Cross section "L" is typical for controlled access freeways. The 46-ft grass median is the minimum desirable width, but variation from this may be permissible depending upon design considerations. Right-of-way requirements are typically 228 ft or greater, depending upon cut and fill requirements.

M: Eight Lanes Divided with Raised Median - Curb and Gutter

Also used for controlled access freeways, cross section "M" may be recommended for freeways going through major urban areas or for routes projected to carry very high volumes of traffic.

N: Five Lanes with Curb & Gutter, Widened Curb Lanes

O: Two Lanes/Shoulder Section

P: Four Lanes Divided with Raised Median – Curb & Gutter, Widened Curb Lanes

If there is sufficient bicycle travel along the thoroughfare to justify a bicycle lane or bikeway, additional right-of-way may be required to contain the bicycle facilities. The North Carolina Bicycle Facilities Planning and Design Guidelines should be consulted for design standards for bicycle facilities. Cross sections "N", "O" and "P" are typically used to accommodate bicycle travel.

General

The urban curb and gutter cross sections all illustrate the sidewalk adjacent to the curb with a buffer or utility strip between the sidewalk and the minimum right-of-way line. This permits adequate setback for utility poles. If it is desired to move the sidewalk farther away from the street to provide additional separation for pedestrians or for aesthetic reasons, additional right-of-way must be provided to insure adequate setback for utility poles.

The right-of-way shown for each typical cross section is the minimum amount required encompassing the street, sidewalks, utilities, and drainage facilities. Cut and fill requirements may require either additional right-of-way or construction easements. Obtaining construction easements is becoming the more common practice for urban roadway construction.

Bicycle Cross Sections

Cross sections B-1, B-2, B-3, B-4, and B-5 are typical bicycle cross sections. Contact the NCDOT Division of Bicycle and Pedestrian Transportation for more information regarding these cross-sections.

B-1: Four Lanes Divided with Wide Outside Lanes

B-2: Five Lanes with Wide Outside Lanes

A widened outside lane is an effective way to accommodate bicyclists riding in the same lane with motor vehicles. With a wide outside lane, motorists do not have to change lanes to pass a bicyclist. The additional width in the outside lane also improves sight distance and provides more room for vehicles to turn onto the roadway. Therefore, on roadways with bicycle traffic, widening the outside lane can improve the capacity of that roadway. Also, by widening the outside lane by a few extra feet both motorists and bicyclists have more space in which to maneuver. This facility type is generally considered for use in urban, suburban, and occasionally rural conditions on roadways where there is a curb and gutter. Wide outside lanes can be applied to several different roadway cross sections.

B-3: Bicycle Lanes on Collector Streets

Bicycle lanes may be considered when it is desirable to delineate road space for preferential use by cyclists. Streets striped with bicycle lanes should be part of a connected bikeway system rather than being an isolated feature. Bicycle lanes function most effectively in mid-block situations by separating bicyclists from overtaking motor vehicles. Integrating bicyclists into complicated intersection traffic patterns can sometimes be problematic. Strip development areas, or roadways with a high number of commercial driveways, tend to be less suitable for bicycle lanes due to frequent and unpredictable motorist turning movements across the path of straight-through cyclists. Striped bike lanes can be effective as a safety treatment, especially for less experienced bicyclists. Two-lane residential/collector streets with lower traffic volume, low-posted speed limit, adequate roadway width for both bike lanes and motor vehicle travel lanes, and an absence of complicated intersections. A median-divided multi-lane roadway with lower traffic volumes and a low volume of right and left turning traffic would be a more appropriate location for bicycle lanes than a high traffic volume undivided multi-lane roadway with a continuous center turn lane. Most bicyclists will choose a route that combines direct access with lower traffic volumes. An origin and destination of less than 4 miles is desirable to generate usage on a facility.

B-4: Wide Paved Shoulders

On urban streets with curb and gutter, wide outside lanes and bicycle lanes are usually the preferred facilities. Shoulders for bicycle use are not typically provided on roadways with curb and gutter. On rural roadways where bicycle travel is common, such as roads in coastal resort areas, wide paved shoulders

are highly desirable. On secondary roadways without curb and gutter where there are few commercial driveways and intersections with other roadways, many bicyclists prefer riding on wide, smoothly paved shoulders.

B-5: Multi-use Pathway

When properly located, multi-use pathway can be a safer type of facility for novice and child bicyclists because they do not have to share the path with motor vehicles. The design standards used for this cross section provides adequate width for two-directional use by both cyclists and pedestrians, provisions of good sight distance, avoidance of steep grades and tight curves, and minimal cross-flow by motor vehicles. A multi-use pathway can serve a variety of purposes, including recreation and transportation. This pathway should not be located immediately adjacent to a roadway because of safety considerations at intersections with driveways and roads. Sidewalks should never be used as a multi-use pathway.

Appendix D

TYPICAL HIGHWAY CROSS SECTIONS

A

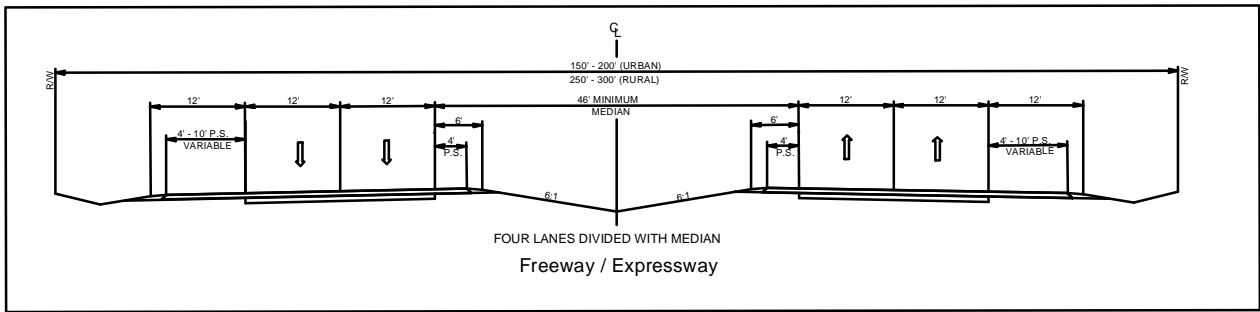

B

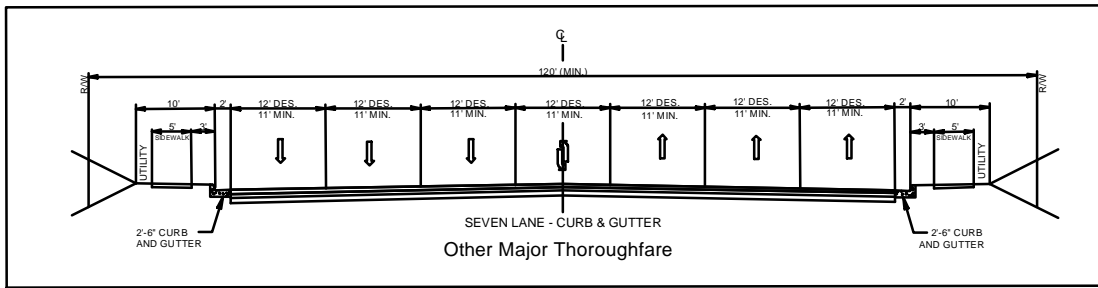

C

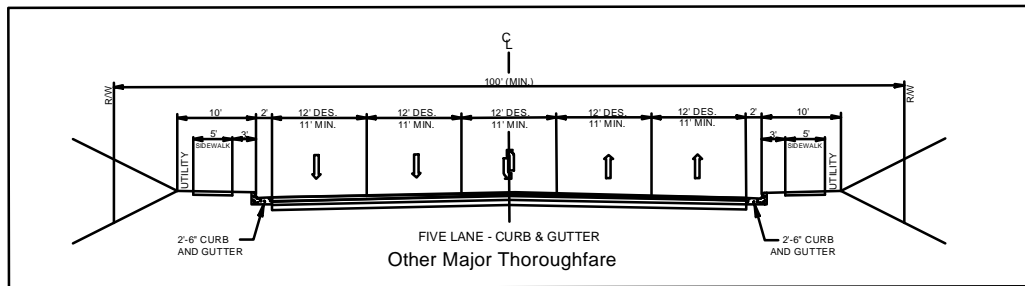

D

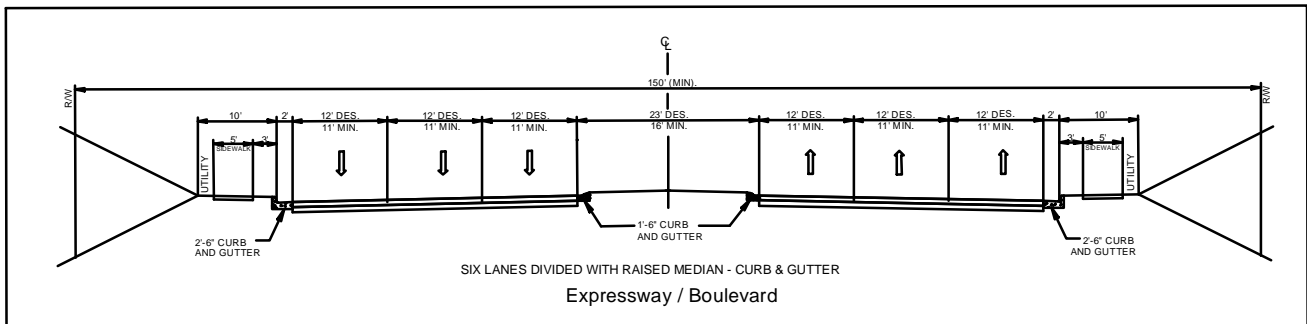

TYPICAL HIGHWAY CROSS SECTIONS

E

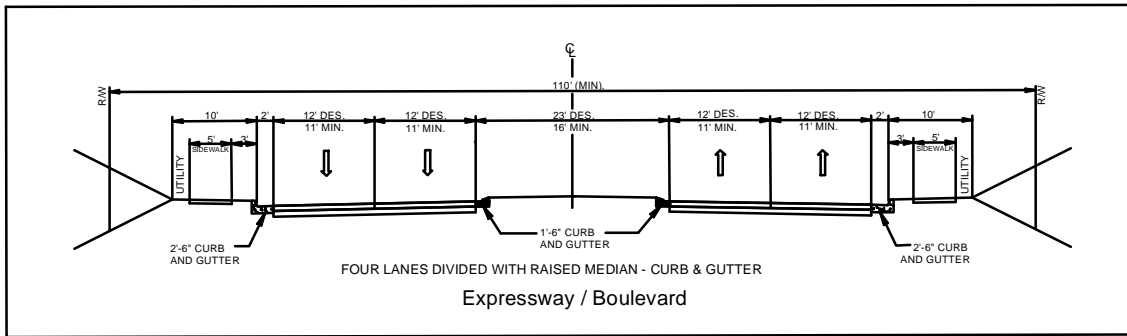

F

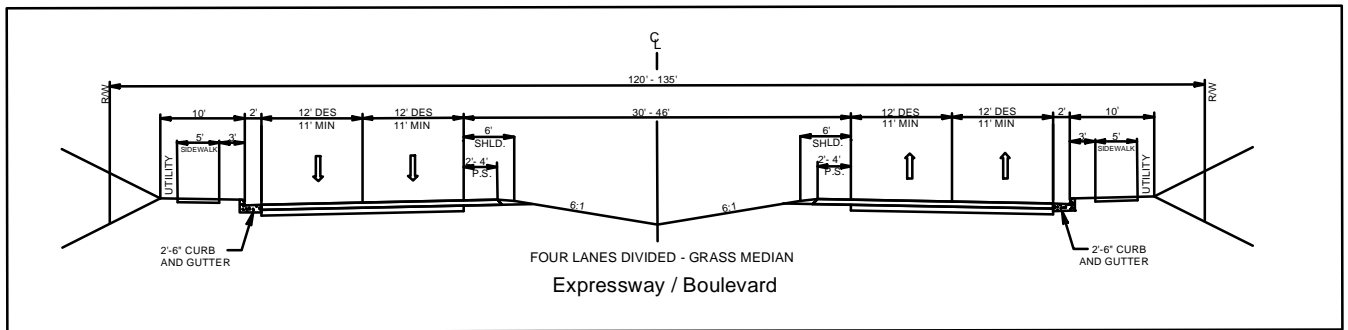

G

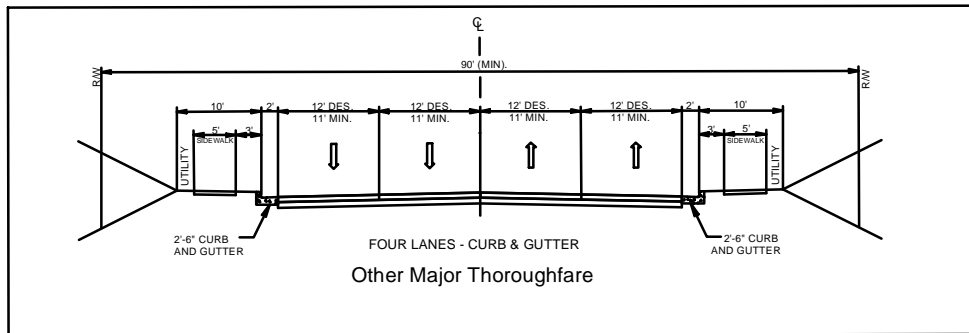

H

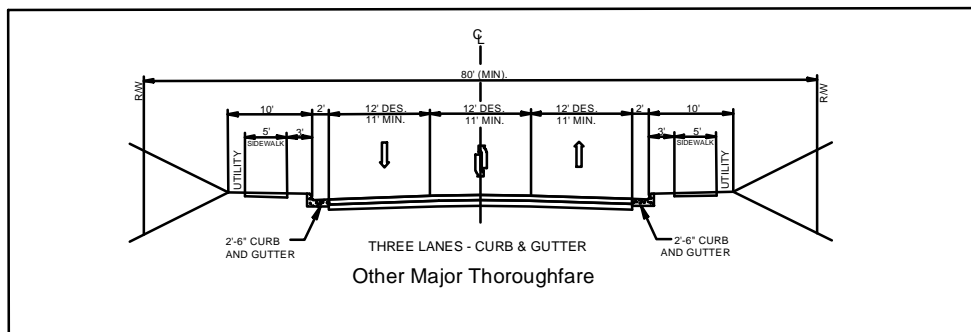

TYPICAL HIGHWAY CROSS SECTIONS

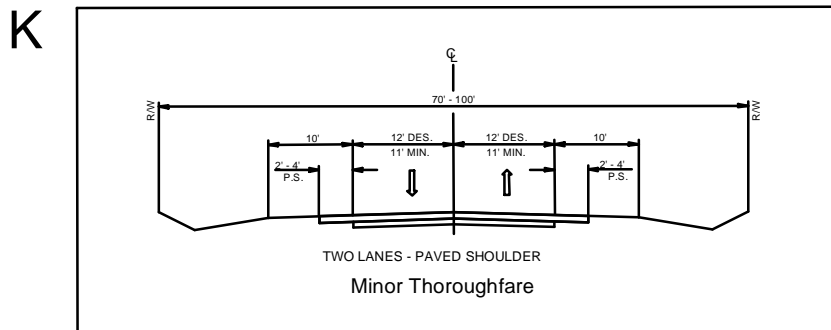
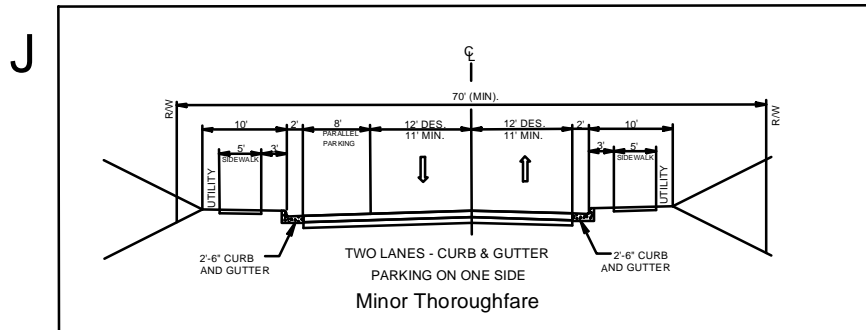
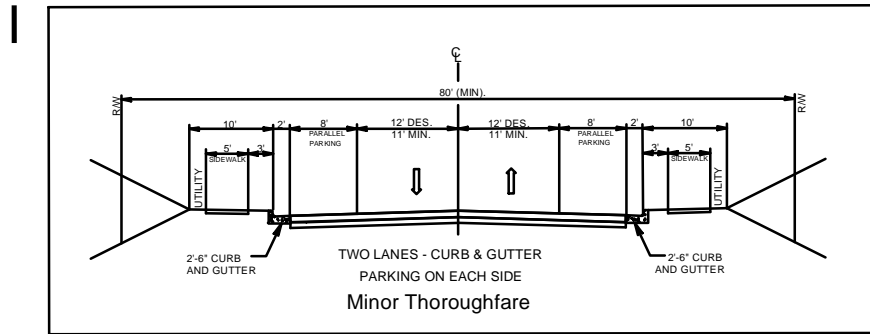

TYPICAL HIGHWAY CROSS SECTIONS

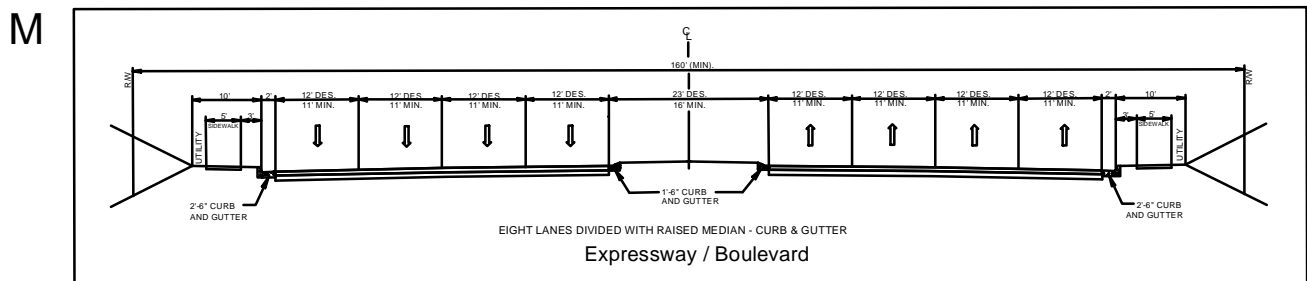
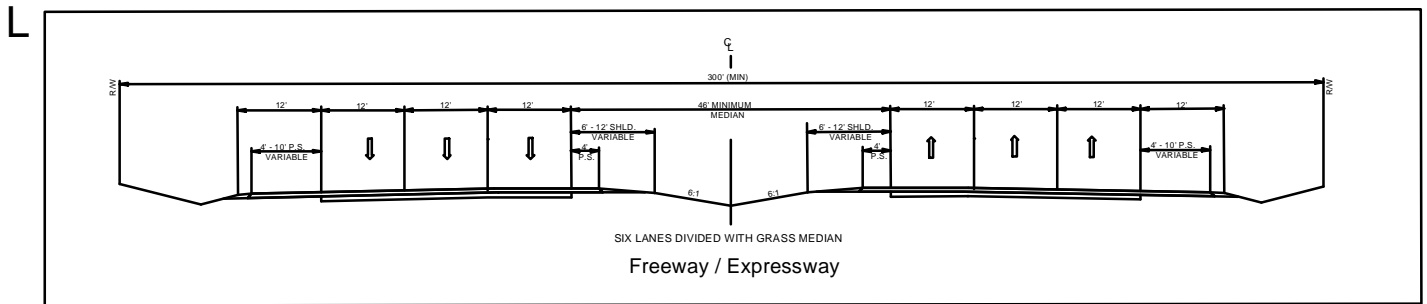

Typical Bicycle Cross Sections

WIDE CURB LANES

B-1 4-LANE MEDIAN DIVIDED TYPICAL SECTION With Wide Outside Lanes

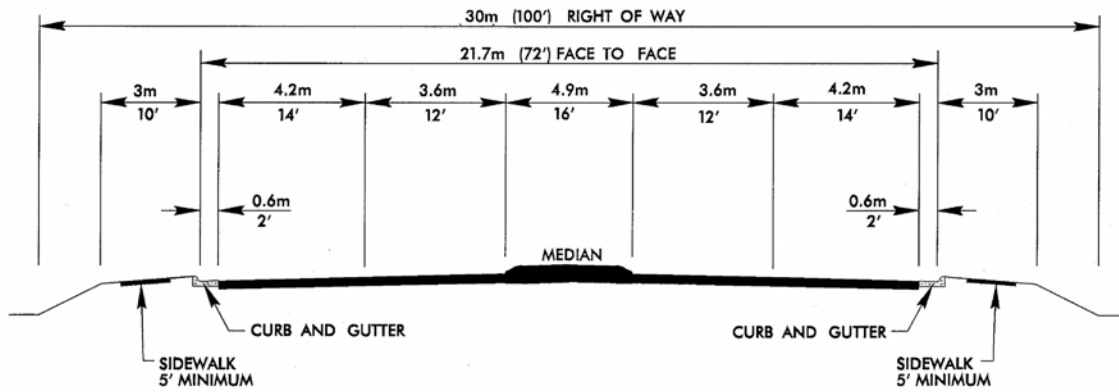

B-2 5-LANE TYPICAL SECTION With Wide Outside Lanes

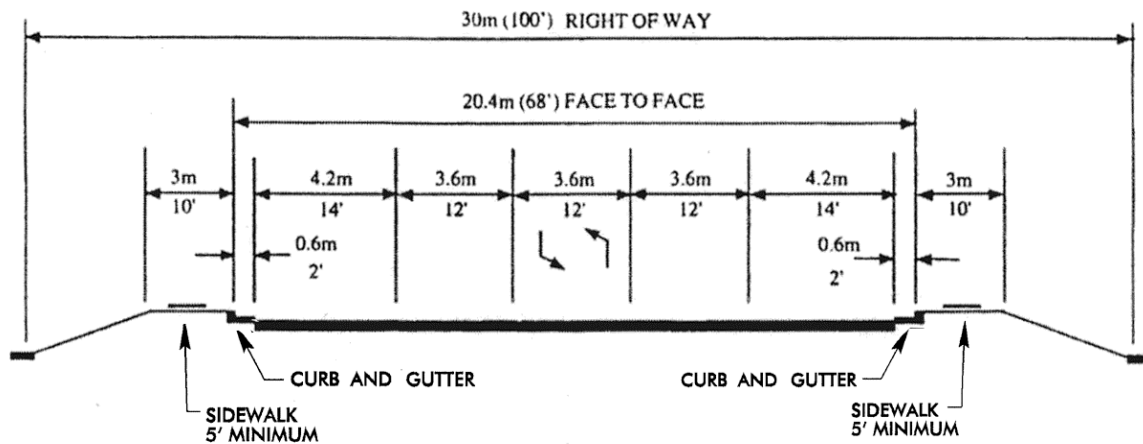

D-11

Typical Bicycle Cross Sections

B-3 BICYCLE LANES ON COLLECTOR STREETS

Existing Roadway

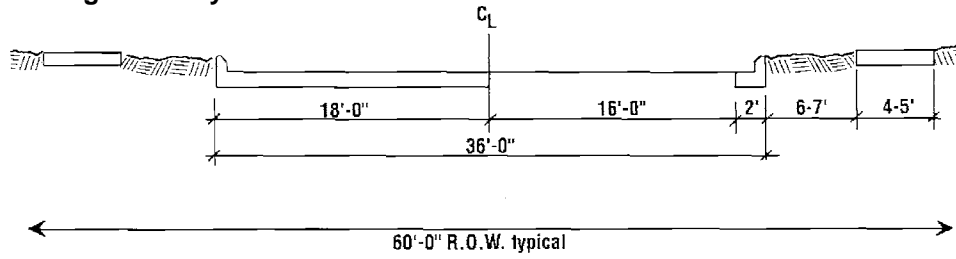

Restriping to Accommodate
Bicycle Lanes (Does Not Allow
On-Street Parking)

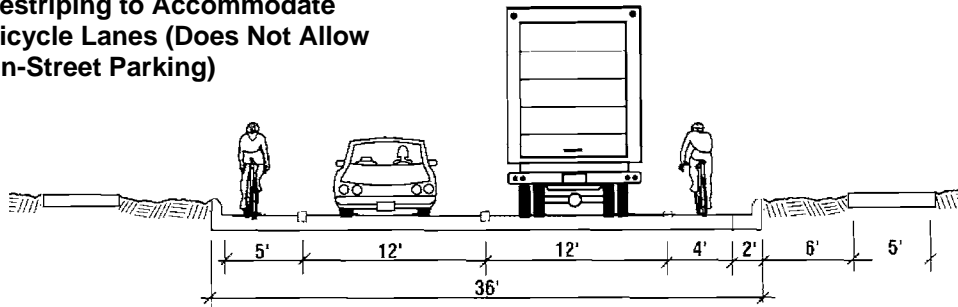

Typical Bicycle Cross Sections

B-4

WIDE PAVED SHOULDERS

Existing Roadway

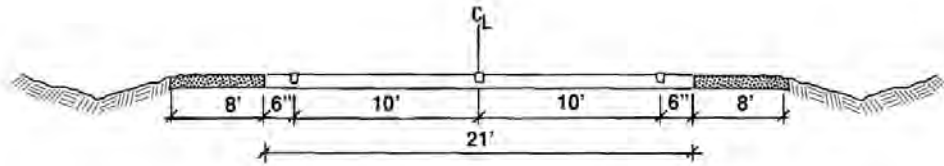

**Roadway Retrofitted with
4-Ft Paved Shoulders**

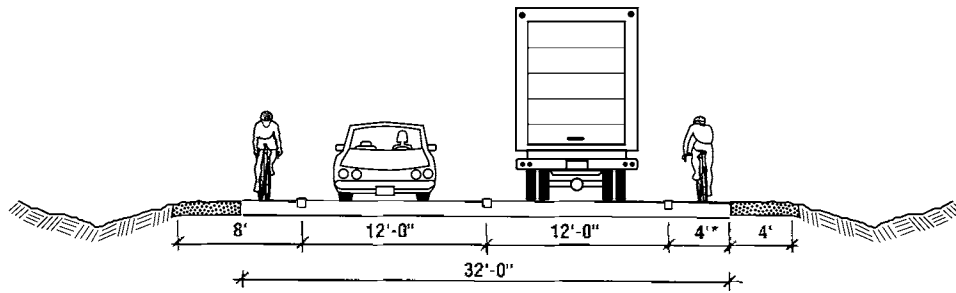

* If speeds are higher than 40 mph,
shoulder widths greater than 4' are
recommended.

D-13

Typical Bicycle Cross Sections

B-5 RECOMMENDED TYPICAL SECTION OF 10-FT ASPHALT PATHWAY With 2-Ft Select Material Shoulder

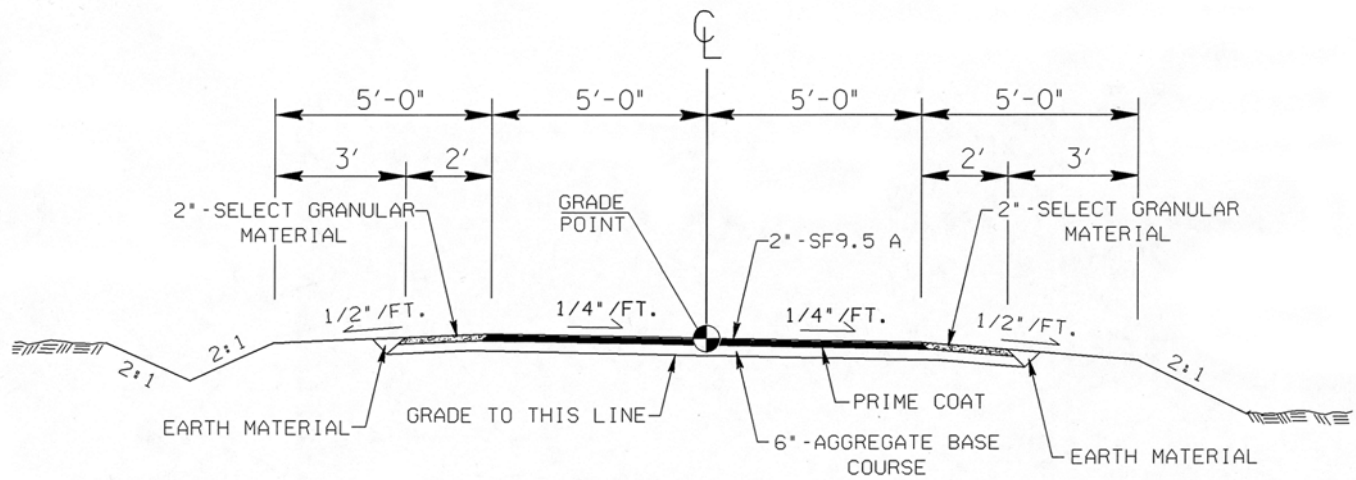

Appendix E

Recommended Subdivision Ordinances

Definitions

Rural Roads

- *Principal Arterial* - A rural link in a highway system serving travel, and having characteristics indicative of substantial statewide or interstate travel and existing solely to serve traffic. This network would consist of Interstate routes and other routes designated as principal arterials.
- *Minor Arterial* - A rural roadway joining cities and larger towns and providing intra-state and inter-county service at relatively high overall travel speeds with minimum interference to through movement.
- *Major Collector* - A road that serves major intra-county travel corridors and traffic generators and provides access to the arterial system.
- *Minor Collector* - A road that provides service to small local communities and traffic generators and provides access to the major collector system.
- *Local Road* - A road that serves primarily to provide access to adjacent land over relatively short distances.

Urban Streets

- *Major Thoroughfares* - Major thoroughfares consist of inter-state, other freeway, expressway, or parkway roads, and major streets that provide for the expeditious movement of high volumes of traffic within and through urban areas.
- *Minor Thoroughfares* - Minor thoroughfares perform the function of collecting traffic from local access streets and carrying it to the major thoroughfare system. Minor thoroughfares may be used to supplement the major thoroughfare system by facilitating minor through traffic movements and may also serve abutting property.
- *Local Street* - A local street is any street not on a higher order urban system and serves primarily to provide direct access to abutting land.

Specific Type Rural or Urban Streets

- *Freeway, expressway, or parkway* - Divided multilane roadways designed to carry large volumes of traffic at high speeds. A *freeway* provides for continuous flow of vehicles with no direct access to abutting property and with access to selected crossroads only by way of interchanges. An *expressway* is a facility with full or partial control of access and generally with grade separations at major intersections. A *parkway* is for non-commercial traffic, with full or partial control of access.

- *Residential Collector Street* - A local street which serves as a connector street between local residential streets and the thoroughfare system. Residential collector streets typically collect traffic from 100 to 400 dwelling units.
- *Local Residential Street* - Cul-de-sacs, loop streets less than 2,500 feet in length, or streets less than 1.0 mile in length that do not connect thoroughfares, or serve major traffic generators, and do not collect traffic from more than 100 dwelling units.
- *Cul-de-sac* - A short street having only one end open to traffic and the other end being permanently terminated and a vehicular turn-around provided.
- *Frontage Road* - A road that is parallel to a partial or full access controlled facility and provides access to adjacent land.
- *Alley* - A strip of land, owned publicly or privately, set aside primarily for vehicular service access to the backside of properties otherwise abutting on a street.

Property

- *Building Setback Line* - A line parallel to the street in front of which no structure shall be erected.
- *Easement* - A grant by the property owner for use by the public, a corporation, or person(s), of a strip of land for a specific purpose.
- *Lot* - A portion of a subdivision, or any other parcel of land, which is intended as a unit for transfer of ownership or for development or both. The word "lot" includes the words "plat" and "parcel".

Subdivision

- *Subdivider* - Any person, firm, corporation or official agent thereof, who subdivides or develops any land deemed to be a subdivision.
- *Subdivision* - All divisions of a tract or parcel of land into two or more lots, building sites, or other divisions for the purpose, immediate or future, of sale or building development and all divisions of land involving the dedication of a new street or change in existing streets. The following shall not be included within this definition nor subject to these regulations:
 - the combination or re-combination of portions of previously platted lots where the total number of lots is not increased and the resultant lots are equal to or exceed the standards contained herein
 - the division of land into parcels greater than 10 acres where no street right-of-way dedication is involved
 - the public acquisition, by purchase, of strips of land for the widening or the opening of streets
 - the division of a tract in single ownership whose entire area is no greater than 2 acres into not more than three lots, where no street right-of-way

dedication is involved and where the resultant lots are equal to or exceed the standards contained herein.

- *Dedication* - A gift, by the owner, of his property to another party without any consideration being given for the transfer. The dedication is made by written instrument and is completed with an acceptance.
- *Reservation* - Reservation of land does not involve any transfer of property rights. It constitutes an obligation to keep property free from development for a stated period of time.

Design Standards

The design of all roads within the Planning Area shall be in accordance with the accepted policies of the North Carolina Department of Transportation, Division of Highways, as taken or modified from the American Association of State Highway and Transportation Officials (AASHTO) manual.

The provision of street rights-of-way shall conform and meet the recommendations of the transportation plan, as adopted by the municipality. The proposed street layout shall be coordinated with the existing street system of the surrounding area. Normally the proposed streets should be the extension of existing streets if possible.

Right-of-way Widths

Right-of-way widths shall not be less than the following and shall apply except in those cases where right-of-way requirements have been specifically set out in the transportation plan.

The subdivider will only be required to dedicate a maximum of 100 feet of right-of-way. In cases where over 100 feet of right-of-way is desired, the subdivider will be required only to reserve the amount in excess of 100 feet. On all cases in which right-of-way is sought for a fully controlled access facility, the subdivider will only be required to make a reservation. It is strongly recommended that subdivisions provide access to properties from internal streets, and that direct property access to major thoroughfares, principle and minor arterials, and major collectors be avoided. Direct property access to minor thoroughfares is also undesirable.

A partial width right-of-way, not less than 60 feet in width, may be dedicated when adjoining undeveloped property that is owned or controlled by the subdivider; provided that the width of a partial dedication be such as to permit the installation of such facilities as may be necessary to serve abutting lots. When the said adjoining property is sub-divided, the remainder of the full required right-of-way shall be dedicated. Minimum right-of-way requirements are shown in Table E-1.

Table E-1: Minimum Right-of-way Requirements

Area Classification	Functional Classification	Minimum ROW
Rural	Principal Arterial (Freeway)	350 feet
	Principal Arterial (Other)	200 feet
	Minor Arterial	100 feet
	Major Collector	100 feet
	Minor Collector	80 feet
	Local Road (see note #1)	60 feet
Urban	Major Thoroughfare	90 feet
	Minor Thoroughfare	70 feet
	Local Street	60 feet
	Cul-de-sac (See note #2)	varies

- 1) The desirable minimum right-of-ways is 60 feet. If curb and gutter is provided, 50 feet of ROW is adequate on local residential streets.
- 2) The ROW dimension will depend on the radius used for vehicle turn-a-around. Distance from edge of pavement of turn-a-around to ROW should not be less than distance from edge of pavement to ROW on street approaching turn-a-round.

Street Widths

Widths for street and road classifications other than local shall be as recommended by the transportation plan. Width of local roads and streets shall be as follows:

- *Local Residential*
 - Curb and Gutter section - 26 feet, face to face curb
 - Shoulder section - 20 feet to edge of pavement, 4 feet for shoulders
- *Residential Collector*
 - Curb and Gutter section - 34 feet, face to face of curb
 - Shoulder section - 20 feet to edge of pavement, 6 feet for shoulders

Geometric Characteristics

The standards outlined below shall apply to all subdivision streets proposed for addition to the State Highway System or Municipal Street System. In cases where a subdivision is sought adjacent to a proposed thoroughfare corridor, the requirements of dedication and reservation discussed under right-of-way shall apply.

- *Design Speed* - The design speed for a roadway should be a minimum of 5 mph greater than the posted speed limit. The design speeds for subdivision type streets are shown in Table E-2.
- *Minimum Sight Distance* - In the interest of public safety, no less than the minimum sight distance applicable shall be provided. Vertical curves that connect each change in grade shall be provided and calculated using the parameters set forth in Table E-3.
- *Superelevation* - Table E-4 shows the minimum radius and the related maximum superelevation for design speeds. The maximum rate of roadway superelevation (e) for rural roads with no curb and gutter is 0.08. The maximum rate of superelevation for urban streets with curb and gutter is 0.06, with 0.04 being desirable.
- *Maximum and Minimum Grades* - The maximum grades in percent are shown in Table E-5. Minimum grade should not be less than 0.5%. Grades for 100 feet each way from intersections (measured from edge of pavement) should not exceed 5%.

Table E-2: Design Speeds

Facility Type	Design Speed (mph)		
	Desirable	Minimum Level	Rolling
<i>Rural</i>			
Minor Collector Roads (AADT Over 2000)	60	50	40
Local Roads ¹ (AADT Over 400)	50	*50	*40
<i>Urban</i>			
Major Thoroughfares ²	60	50	40
Minor Thoroughfares	40	30	30
Local Streets	30	**30	**20

*Based on AADT of 400-750. Where roads serve limited area and small number of units, reduce minimum design speed. **Based on projected ADT of 50-250. (Refer to NCDOT Roadway Design Manual page 1-1B)

¹ Local Roads including Residential Collectors and Local Residential.

² Major Thoroughfares other than Freeways or Expressways.

Table E-3: Sight Distance

Design Speed Distance (mph)	Stopping Sight Distance (feet)		Minimum K ¹ Values (feet)		Passing Sight Distance (feet)
	Desirable	Minimum	Crest Curve	Sag Curve	For 2- lanes
30	200	200	30	40	1100
40	325	275	60	60	1500
50	475	400	110	90	1800
60	650	525	190	120	2100

Note: General practice calls for vertical curves to be multiples of 50 feet. Calculated lengths shall be rounded up in each case. (Reference NCDOT Roadway Design Manual page 1-12 T-1)

¹K is a coefficient by which the algebraic difference in grade may be multiplied to determine the length of the vertical curve, which will provide the desired sight distance. Sight distance provided for stopped vehicles at intersections should be in accordance with "A Policy on Geometric Design of Highways and Streets, 1990".

Table E-4: Superelevation

Design Speed Curve (mph) e=0.08	Minimum Radius of Maximum e ¹			Maximum Degree of		
	e=0.04	e=0.06	e=0.08	e=0.04	e=0.06	
30	302	273	260	19 00'	21 00'	22 45'
60	573	521	477	10 00'	11 15'	12 15'
80	955	955	819	6 00'	6 45'	7 30'
100	1,637	1,432	1,146	3 45'	4 15'	4 45'

¹ e = rate of roadway superelevation, foot per foot

Note: (Reference NCDOT Roadway Design Manual page 1-12 T-6 thru T-8)

Table E-5: Maximum Vertical Grade

Facility Type and Design Speed (mph) Mountainous	Minimum Grade in Percent		
	Flat	Rolling	
RURAL			
Minor Collector Roads*			
20	7	10	12
30	7	9	10
40	7	8	10
50	6	7	9
60	5	6	8
70	4	5	6
Local Roads* ¹			
20	-	11	16
30	7	10	14
40	7	9	12
50	6	8	10
60	5	6	-
URBAN			
Major Thoroughfares ²			
30	8	9	11
40	7	8	10
50	6	7	9
60	5	6	8
Minor Thoroughfares*			
20	9	12	14
30	9	11	12
40	9	10	12
50	7	8	10
60	6	7	9
70	5	6	7
Local Streets*			
20	-	11	16
30	7	10	14
40	7	9	12
50	6	8	10
60	5	6	-

Note: *For streets and roads with projected annual average daily traffic less than 250 or short grades less than 500 ft long, grades may be 2% steeper than the values in the above table. (Reference NCDOT Roadway Metric Design Manual page 1-12 T-3)

¹ Local Roads including Residential Collectors and Local Residential.

² Major Thoroughfares other than Freeways or Expressways.

Intersections

1. Streets shall be laid out so as to intersect as nearly as possible at right angles, and no street should intersect any other street at an angle less than sixty-five (65) degrees.
2. Property lines at intersections should be set so that the distance from the edge of pavement, of the street turnout, to the property line will be at least as great as the distance from the edge of pavement to the property line along the intersecting streets. This property line can be established as a radius or as a sight triangle. Greater offsets from the edge of pavement to the property lines will be required, if necessary, to provide sight distance for the stopped vehicle on the side street.
3. Offset intersections are to be avoided. Intersections that cannot be aligned should be separated by a minimum length of 200 feet between survey centerlines.

Cul-de-sacs

Cul-de-sacs shall not be more than 500 feet in length. The distance from the edge of pavement on the vehicular turn around to the right-of-way line should not be less than the distance from the edge of pavement to right-of-way line on the street approaching the turn around. Cul-de-sacs should not be used to avoid connection with an existing street or to avoid the extension of an important street.

Alleys

1. Alleys shall be required to serve lots used for commercial and industrial purposes except that this requirement may be waived where other definite and assured provisions are made for service access. Alleys shall not be provided in residential subdivisions unless necessitated by unusual circumstances.
2. The width of an alley shall be at least 20 feet.
3. Dead-end alleys shall be avoided where possible, but if unavoidable, shall be provided with adequate turn around as may be required by the planning board.

Permits for Connection to State Roads

An approved permit is required for connection to any existing state system road. This permit is required prior to any construction on the street or road. The application is available at the office of the District Engineer of the Division of Highways.

Offsets To Utility Poles

Poles for overhead utilities should be located clear of roadway shoulders, preferably a minimum of at least 30 feet from the edge of pavement. On streets with curb and gutter, utility poles shall be set back a minimum distance of 6 feet from the face of curb.

Wheel Chair Ramps

All street curbs being constructed or reconstructed for maintenance purposes, traffic operations, repairs, correction of utilities, or altered for any reason, shall provide wheelchair ramps for the physically handicapped at intersections where both curb and gutter and sidewalks are provided and at other major points of pedestrian flow.

Horizontal Width on Bridge Deck

The clear roadway widths for new and reconstructed bridges serving two-lane, two-way traffic should be as follows:

- shoulder section approach:
 - * under 800 ADT design year - minimum 28 feet width face to face of parapets, rails, or pavement width plus 10 feet, whichever is greater,
 - * 800 - 2000 ADT design year - minimum 34 feet width face to face of parapets, rails, or pavement width plus 12 feet, whichever is greater,
 - * over 2000 ADT design year - minimum width of 40 feet, desirable width of 44 feet width face to face of parapets or rails;
- curb and gutter approach:
 - * under 800 ADT design year - minimum 24 feet face to face of curbs,
 - * over 800 ADT design year - width of approach pavement measured face to face of curbs,
 - * where curb and gutter sections are used on roadway approaches, curbs on bridges shall match the curbs on approaches in height, in width of face to face curbs, and in crown drop; the distance from face of curb to face of parapet or rail shall be a minimum of 1.5 feet, or greater if sidewalks are required.

The clear roadway widths for new and reconstructed bridges having 4 or more lanes serving undivided two-way traffic should be as follows:

- shoulder section approach - width of approach pavement plus width of usable shoulders on the approach left and right. (shoulder width 8 feet minimum, 10 feet desirable)
- curb and gutter approach - width of approach pavement measured face to face of curbs.

Appendix F
Projection of Population and Employment Data
for the Eden Planning Area from 2007 to 2035

Before projecting the population and housing data to the design year of 2035, the current population and housing data must be determined. For the Eden Planning Area, the population and persons per household was derived from 2000 Census data. It was then updated to reflect the number of dwelling units that had been added between 2000 and 2007. Using this data, the population was determined to be 25,517 and the number of dwelling units was determined to be 10,628.

Population and Housing Projections

In order to project the base year employment and population data, a target population was determined for the design year of 2035. Much like determining an interest rate, a population growth rate has to be determined. To do this historic population data was gathered from the North Carolina Office of State Budget and Management for Rockingham County and the City of Eden. Past trends in Census Data from 1970 to 2000 for Rockingham County and Eden were looked at along with the growth in population within the Eden Planning Area via 1990 and 2000 Census data.

Population data is listed in the tables below with the future information projected by the North Carolina Office of State Budget and Management as well as the 1990 and 2000 Census Data for the Eden Planning Area.

Location	1980	1990	2000	2007	2010	2020	2030
North Carolina	5,880,095	6,632,448	8,046,491	9,069,398*	9,349,175*	10,709,704*	12,447,597*
Rockingham County	83,426	86,064	91,928	91,646*	92,779*	94,561*	95,922*
City of Eden	15,672	15,238	15,908	15,666*	16,055**	16,363**	16,599**

* Projections by the North Carolina State Data Center

** Projections for Eden provided by the NCDOT Transportation Planning Branch

Eden Planning Area information based on the 1990 and 2000 Census Data

	1990 Census	2000 Census
Eden Planning Area	25,252	25,131

Using the known data, a growth rate was determined with the formula:

- $F = P (1+r)^N$ where:
- F = Future Population
- P = Present Population
- r = Rate of Growth
- N = Number of Years

Rockingham County showed the following growth rates:

Growth Rates Per Year	1970-2000	1980-2000	1990-2000
North Carolina	1.94%	1.84%	2.13%
Rockingham County	0.90%	0.51%	0.68%
Eden City Limits	0.01%	0.08%	0.44%
Eden Planning Area	N/A	N/A	-0.05%

The growth rate for the Eden Planning Area from 2000 to 2007 is 0.22% per year. Comparing with the Rockingham County growth rates, the Eden City Limits growth rates, and the Eden Planning Area growth rates, a planning growth rate of 0.22% per year is reasonable. This is also consistent with the previous Eden Thoroughfare Plan, which estimated a growth rate of 0.21% per year. Continuing this growth rate for the Eden Planning Area will result in future populations listed in the table below:

Population Projection	2015	2025	2035
Eden Planning Area	25,970	26,547	27,136

To determine future housing numbers the Eden Planning Area population developed above must be converted to dwelling units. To do this past persons/dwelling units data for Rockingham County were graphed and a trend line was extended to the design year of 2035. This is displayed in the table below:

Rockingham County	Total HH Population	Total Households	Persons/Dwelling Unit
1990	85,242	33,446	2.55
2000	90,742	36,989	2.45
2015	98,992	42,304	2.34
2025	104,492	45,847	2.28
2035	109,992	49,390	2.23

Using these persons/dwelling units, the Eden Planning Area households can be determined in the table below:

Eden Planning Area	Population	Households	Persons/Dwelling Unit
2007	25,517	10,628	2.40
2015	25,970	11,098	2.34
2025	26,547	11,643	2.28
2035	27,136	12,169	2.23

These houses should be distributed throughout the Eden Planning Area. When completing the housing distribution throughout the Eden Planning Area, it should be kept in mind that there is a limited amount of land on which to build houses. Also, the Eden Land Use Plan recommends which areas within the Eden Planning Area should be developed for housing. As the zoning density is reached, zones of high growth will peak and stabilize, some houses will drop from high trip generators, and some houses will not last 30 years. This is why

each traffic analysis zone (TAZ) within the Eden Planning Area must be considered on an individual basis.

Employment Projections

Employment figures for 2007 in the Eden Planning Area were gathered for Eden and the final total was 8,243 jobs. To determine the number of future jobs in the Eden Planning Area, a ratio was taken with the present number of jobs over the present population.

$$\begin{aligned} 2007 \text{ Employment} &= 8,243 = 0.3230 \\ 2007 \text{ Population} &= 25,517 \end{aligned}$$

Comparing the current employment and population ratio with past studies, there has been a considerable decrease in the total employment, while the total population has held fairly constant. This could be explained by the closure of several textile industries as well as other supporting industries over the past decade. While the employment to population ratio may continue to decrease, the rate is expected to level off and slowly increase from 2007 to 2035. Assuming slow and continued growth, the employment to population ratio as well as the total future employment is shown in the following table:

Year	Population	Employment/Population Ratio	Employment
2007	25,517	0.3229	8,240
2015	25,970	0.3400	8,830
2025	26,547	0.3700	9,822
2035	27,136	0.4000	10,854

The same zones used to allocate housing will be used to allocate employment. Percentages from the North American Industry Classification System should be determined based on the existing breakdown and the Eden Land Use Plan recommendations and expectations for the future. The existing breakdown is shown in the table below:

2007	Employment	Percentage
Industry	2,752	33.40%
Retail	952	11.55%
Highway Retail	1,084	13.16%
Office	881	10.69%
Service	1,223	14.84%
School	538	6.53%
Hospital	810	9.83%

Once these future projections are determined, the number of jobs for each classification can be calculated and inserted into the table of future employment below:

2015	Employment	Percentage
Industry	2737	31%
Retail	1060	12%
Highway Retail	1236	14%
Office	971	11%
Service	1325	15%
School	618	7%
Hospital	883	10%

2025	Employment	Percentage
Industry	2947	30%
Retail	1179	12%
Highway Retail	1473	15%
Office	1080	11%
Service	1572	16%
School	688	7%
Hospital	884	9%

2035	Employment	Percentage
Industry	3148	29%
Retail	1302	12%
Highway Retail	1682	15.5%
Office	1194	11%
Service	1845	17%
School	760	7%
Hospital	923	8.5%

We can now total the number of jobs added by classification type in the table below:

Employment Type	Projected Employment Change 2007-2035
Industry	396
Retail	350
Highway Retail	598
Office	313
Service	622
School	222
Hospital	113

Now these numbers must be distributed throughout each TAZ in the Eden Planning Area. Refer to Figure F-1 for a map of the TAZ's within the Eden Planning Area.

TAZ #	07 HH	35 HH	07 Ind.	35 Ind.	07 Retail	35 Retail	07 Office	35 Office	07 Service	35 Service	07 Hwy Retail	35 Hwy Retail	07 School	35 School	07 Hospital	35 Hospital
1	220	220	94	94	19	35	75	80	194	213	7	7	0	0	0	0
2	191	191	7	7	0	5	1	10	46	57	0	0	0	0	0	0
3	131	131	44	44	0	4	0	0	4	6	5	5	0	0	0	0
4	121	121	0	0	4	8	7	10	4	4	23	28	0	0	0	0
5	405	425	0	10	0	0	3	3	1	1	0	0	0	0	0	0
6	192	205	36	60	15	25	23	26	13	19	18	28	0	0	0	0
7	244	267	18	18	0	9	52	60	31	38	0	0	84	123	0	0
8	229	229	0	0	26	36	4	6	23	25	7	15	0	0	0	0
9	103	103	0	0	7	17	10	15	6	8	22	22	0	0	0	0
10	187	190	11	11	3	3	0	0	13	14	0	0	73	107	0	0
11	315	338	0	0	0	0	0	0	0	0	8	14	0	0	0	0
12	142	180	8	8	0	0	0	0	0	0	0	0	0	0	0	0
13	406	436	21	21	3	6	0	0	13	19	6	10	0	0	0	0
14	63	83	46	46	0	2	2	2	0	0	0	0	0	0	0	0
15	201	201	3	3	0	0	0	0	0	0	6	6	0	0	0	0
16	243	255	7	7	0	0	7	7	113	113	0	0	0	0	0	0
17	53	69	0	0	0	0	0	0	0	0	0	0	0	0	0	0
18	144	144	10	10	0	0	0	0	2	2	5	5	0	0	0	0
19	248	272	5	5	0	0	0	0	3	3	0	0	0	0	0	0
20	115	131	1	1	0	0	0	0	0	0	0	0	0	0	0	0
21	178	192	2	2	0	0	0	0	0	0	1	1	0	0	0	0
22	130	146	0	0	0	0	0	0	0	0	0	0	0	0	0	0
23	179	198	0	0	0	0	0	0	0	0	0	0	0	0	0	0
24	180	210	8	30	0	0	0	0	0	0	0	0	0	0	0	0
25	152	182	15	15	0	0	1	1	0	0	0	0	0	0	0	0
26	103	113	9	9	6	6	0	0	0	0	0	0	0	0	0	0
27	143	153	8	8	0	0	2	2	0	0	0	0	0	0	0	0
28	133	148	12	12	0	0	0	0	0	0	0	0	0	0	0	0
29	178	195	0	0	0	0	0	0	0	0	0	0	0	0	0	0
30	147	160	23	23	0	0	0	0	2	2	28	34	0	0	0	0
31	155	176	0	0	0	0	2	2	0	0	0	0	0	0	0	0
32	57	65	6	6	0	0	0	0	0	0	0	0	0	0	0	0
33	190	210	4	4	5	5	0	0	0	0	2	2	0	0	0	0

TAZ #	07 HH	35 HH	07 Ind.	35 Ind.	07 Retail	35 Retail	07 Office	35 Office	07 Service	35 Service	07 Hwy Retail	35 Hwy Retail	07 School	35 School	07 Hospital	35 Hospital
34	137	161	3	3	0	0	0	0	0	0	0	0	0	0	0	0
35	70	95	0	0	0	0	0	0	0	0	0	0	0	0	0	0
36	181	229	0	0	0	0	0	0	0	0	0	0	0	0	0	0
37	87	123	5	5	0	0	0	0	0	0	37	44	58	59	0	0
38	106	193	21	40	87	74	148	166	166	284	115	218	0	0	0	0
39	136	146	135	135	101	61	98	235	235	318	237	355	0	0	0	0
40	76	81	24	24	16	69	77	1	1	10	0	0	0	0	0	0
41	173	173	55	70	19	28	0	0	11	25	0	0	0	0	0	0
42	131	131	9	9	0	0	0	0	3	3	0	0	0	0	0	0
43	114	130	12	12	1	0	0	22	22	30	0	0	0	0	0	0
44	103	120	0	0	0	0	0	0	0	0	0	0	0	0	0	0
45	383	519	1	1	0	0	0	0	0	0	17	17	0	0	0	0
46	144	161	2	2	7	15	0	5	0	10	0	20	0	0	0	0
47	195	210	1	20	0	0	0	0	1	16	0	0	0	0	0	0
48	151	198	67	85	111	189	1	10	116	223	9	48	0	0	0	0
49	159	189	585	650	0	0	11	15	0	0	0	0	0	0	0	0
50	31	39	317	360	8	8	39	46	0	0	0	0	0	0	0	0
51	50	62	0	0	1	7	11	20	33	56	59	72	90	131	0	0
52	112	122	232	222	6	6	8	15	4	30	6	6	180	263	0	0
53	40	40	36	55	0	0	95	120	0	0	0	0	0	0	0	0
54	36	36	87	90	0	0	0	0	0	0	0	0	0	0	0	0
55	97	97	0	0	1	3	0	0	0	0	5	14	0	0	0	0
56	163	163	0	0	8	12	4	8	0	0	7	13	0	0	0	0
57	229	258	141	119	0	3	1	4	7	35	0	0	53	77	0	0
58	145	145	0	0	0	3	0	0	0	0	0	0	0	0	0	0
59	258	263	20	20	0	0	0	0	0	0	0	0	0	0	0	0
60	75	105	0	0	0	0	0	0	0	0	0	0	0	0	0	0
61	156	173	0	0	3	3	0	0	22	48	0	0	0	0	0	0
62	352	390	192	343	12	24	0	0	0	0	0	0	0	0	0	0
63	101	111	0	0	0	0	16	30	12	25	0	0	0	0	810	923
64	129	205	0	0	0	0	0	0	1	10	12	28	0	0	0	0
65	90	122	9	9	0	0	0	0	0	0	0	0	0	0	0	0
66	340	640	400	420	483	566	302	374	121	198	442	670	0	0	0	0
TOT	10628	12169	2752	3148	952	1302	881	1194	1223	1845	1084	1682	538	760	810	923

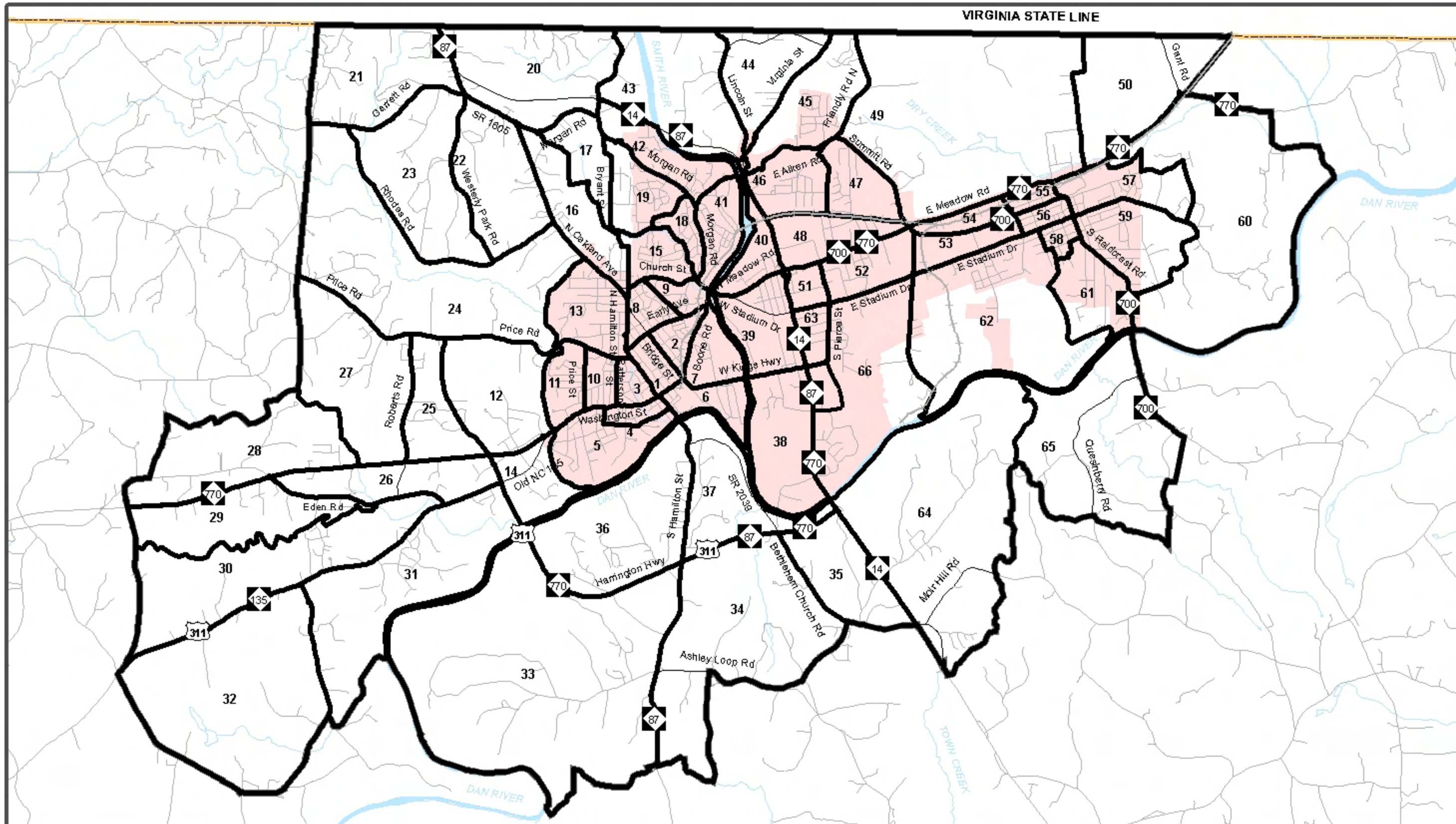

- 66 Traffic Analysis Zones (TAZs)
- Network Roads
- ▭ Planning Boundary
- ▭ County Boundary
- ▭ City Limits

City of Eden
Figure F-1:
Traffic Analysis Zones

Base map date: September 2007

Scale: 0 0.25 0.5 1 1.5 2 Miles

Appendix G Public Involvement

As part of the public involvement process, a transportation and land use survey was administered in the late part of 2006. The survey was mailed out to Eden residents with their monthly water bill and was also available at city hall, the library, and online. The survey results are below:

Survey Results

GOAL:	Very Important	Important	Slightly Important	Not Important	Neutral/ No Opinion	TOTAL
Increased Transportation Choices <i>More and safer opportunities to walk and bike to destinations</i>	145 33.7%	141 32.8%	80 18.6%	48 11.2%	16 3.7%	430
Increased Public Transportation Options <i>Bus or rail service to destinations; Park-n-ride lots to facilitate carpooling, vanpooling, and transit service</i>	107 24.9%	125 29.1%	107 24.9%	76 17.7%	15 3.5%	430
Faster Automobile Travel Times <i>Higher-speed roads with more lanes and fewer intersections; more connector roads; less congestion</i>	84 19.7%	120 28.1%	102 23.9%	103 24.1%	18 4.2%	427
Community and Rural Culture Preservation <i>Keeping businesses in downtown areas; preservation of existing buildings and neighborhoods; maintaining the rural culture and landscape</i>	200 46.6%	135 31.5%	67 15.6%	21 4.9%	6 1.4%	429
Environmental Protection <i>Minimizing the impact on wetlands, streams, and wildlife areas; reducing air pollution</i>	246 57.6%	118 27.6%	46 10.8%	12 2.8%	5 1.2%	427
Economic Growth <i>Building or improving roads and railways to attract new businesses and to allow existing businesses to expand</i>	257 60.2%	124 29.0%	29 6.8%	13 3.0%	4 0.9%	427
Service of Special Needs <i>Better transportation services for poor, elderly, and disabled residents</i>	208 48.4%	148 34.4%	56 13.0%	14 3.3%	4 0.9%	430

STRATEGY:	Very Important	Important	Slightly Important	Not Important	Neutral/ No Opinion	TOTAL
Building additional traffic lanes	103 24.0%	143 33.3%	111 25.8%	60 14.0%	13 3.0%	430
Controlling the frequency and locations of driveways and cross streets that access the road	83 19.9%	147 35.3%	127 30.5%	38 9.1%	22 5.3%	417
Making improvements to intersections, better traffic signal timing	223 52.8%	141 33.4%	36 8.5%	14 3.3%	8 1.9%	422

STRATEGY:	Very Important	Important	Slightly Important	Not Important	Neutral/ No Opinion	TOTAL
Keep and attract businesses into downtown areas	212 49.8%	153 35.9%	38 8.9%	18 4.2%	5 1.2%	426
Support the protection and rehabilitation of existing neighborhoods	222 52.4%	159 37.5%	26 6.1%	10 2.4%	7 1.7%	424
Limit development outside City Limits	60 14.7%	99 24.2%	115 28.1%	108 26.4%	27 6.6%	409
Encourage new commercial development in clusters or activity centers	117 27.9%	174 41.5%	76 18.1%	30 7.2%	22 5.3%	419

STRATEGY:	Very Important	Important	Slightly Important	Not Important	Neutral/ No Opinion	TOTAL
Minimize the impact of development on wetlands, streams and wildlife areas	214 50.1%	120 28.1%	61 14.3%	18 4.2%	14 3.3%	427
Encourage the provision of open space and recreation facilities in private development	152 36.2%	146 34.8%	71 16.9%	27 6.4%	24 5.7%	420
Protect farmland and highly productive agricultural lands	222 52.5%	127 30.0%	49 11.6%	13 3.1%	12 2.8%	423

STRATEGY:

	Very Important	Important	Slightly Important	Not Important	Neutral/ No Opinion	TOTAL
Focus efforts on attracting new businesses and jobs to the area	328 76.5%	77 17.9%	11 2.6%	8 1.9%	5 1.2%	429
Concentrate on helping existing businesses expand and grow	283 67.1%	116 27.5%	12 2.8%	7 1.7%	4 0.9%	422
Extend water and sewer lines to promote economic development	210 49.5%	128 30.2%	52 12.3%	21 5.0%	13 3.1%	424
Discourage industrial development in areas that would impact the quality of life for existing residents	221 52.1%	125 29.5%	51 12.0%	15 3.5%	12 2.8%	424

Desired Access to Municipalities and Major Roads

	Most Desirable			Least Desirable		
	1	2	3	4	5	TOTAL
Greensboro	135 75.4%	18 10.1%	12 6.7%	9 5.0%	5 2.8%	179
Burlington	87 55.1%	22 13.9%	32 20.3%	10 6.3%	7 4.4%	158
Winston-Salem	114 64.0%	24 13.5%	20 11.2%	10 5.6%	10 5.6%	178
Danville, VA	144 77.8%	20 10.8%	14 7.6%	4 2.2%	3 1.6%	185
Martinsville, VA	109 66.5%	23 14.0%	18 11.0%	6 3.7%	8 4.9%	164
I-40	69 57.5%	13 10.8%	21 17.5%	6 5.0%	11 9.2%	120
US 29	64 52.5%	21 17.2%	20 16.4%	7 5.7%	10 8.2%	122
US 220	105 69.1%	24 15.8%	10 6.6%	6 3.9%	7 4.6%	152
US 311	37 34.9%	7 6.6%	27 25.5%	15 14.2%	20 18.9%	106

Appendix H Previous Thoroughfare Plan Map

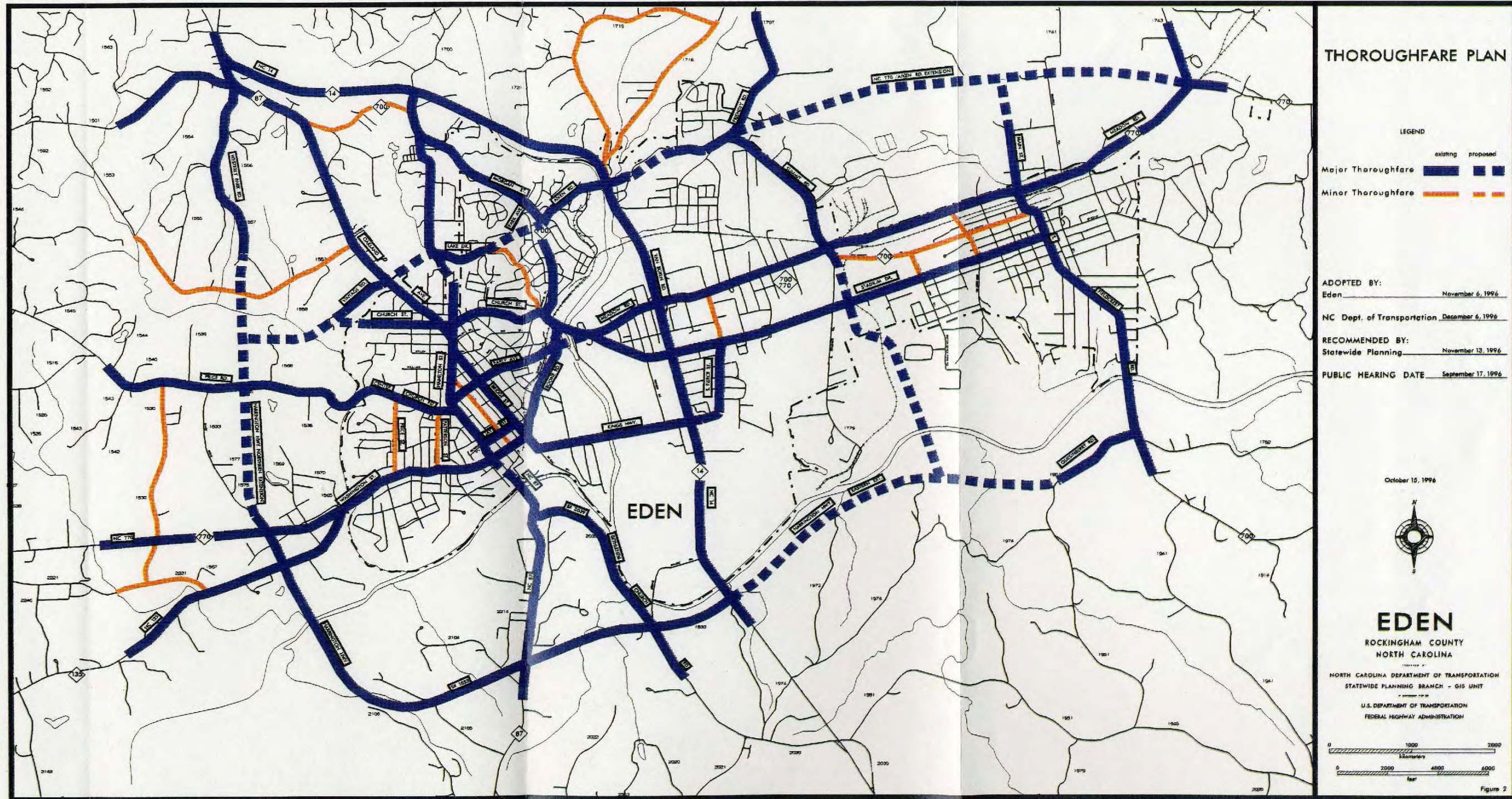

Appendix I

Transportation Improvement Program Project Process

The process for requesting projects to be included in the Transportation Improvement Program (TIP) is described briefly in this appendix.

The local representatives should first decide which projects from the CTP they would like funded in the TIP. A TIP request for a few carefully selected projects is likely to be more effective than requesting all the projects proposed in the thoroughfare plan. These projects should be prioritized by the local representatives and summarized briefly.

After determining which projects are the highest priority for the area, a TIP project request should be sent to the Board of Transportation Member from the municipality's or county's respective district. The TIP project request should include a letter with a prioritized summary of requested projects, as well as a TIP candidate project request form and a project location map for each project.

Currently, the project prioritization process is being revised by NCDOT. For information, contact NCDOT's Strategic Planning Office (SPOT). SPOT contact information is located in Appendix A.

Appendix J

Travel Demand Modeling Process¹

Travel Demand Modeling estimates travel on the transportation system and gives a preview of travel on proposed facilities. Travel patterns are based on relationships developed from survey data between employment sites, housing, and transportation facilities. Forecasts assume that travel patterns will stay the same for a given period and can therefore demonstrate future travel flows.

What makes up a Model?

Network

The network consists of an abstract of the travel system. The roadway is a simplified representation of streets that provide for general circulation within a given region. It is based on a system of nodes and links. Nodes are generally street intersection points, while links connect the nodes and represent streets and provide information on operating characteristics such as type and length of facility, number of lanes, etc. Also represented are gateways or cordon stations.

Socioeconomic Data

The amount and type of travel depend on the land use parameters input into the model. Traffic Analysis Zones (TAZ) are the analysis units of the model. Land use data are incorporated into TAZs, which range in size. Boundaries generally include the regional network area and natural or manmade dividers, such as canals and railroads, which naturally limit opportunities for trip crossings.

Land use is described in terms of type, intensity and location. This data is used in the trip generation process to estimate factors such as the number of trips that a household or employee will produce. Data is developed for a base and future year. Household Data includes population and is often broken down into various categories such as single-family households with two or more autos or multiple family households with no autos.

¹ <http://www.hpdot.net/hpmpo/plans/modeling.htm>

In simple terms, the four steps in travel demand modeling are the following:

- 1. Trip Generation**
- 2. Trip Distribution**
- 3. Mode Choice**
- 4. Trip Assignment**

Trip Generation

Trip generation takes socioeconomic data, and based on historical survey information, estimates the number of person trips produced and attracted within each Transportation Analysis Zones (TAZ). These trip productions and attractions are generally called “trip ends”.

Trip Distribution

Trip distribution determines where a trip develops and where the trip will go. Trips are connected between TAZ-based data previously input into the model. Trip generation assumes a person is more likely to travel to a nearby zone with many amenities such as employment, shopping, etc. than to a further zone with few amenities.

Known as a “gravity model” this process derives its name and basic working premise from Newton’s law of gravity, which states that:

The attractive force between two bodies is directly related to their size and inversely related to the distance between them.

Therefore, the number of trips between areas is directly related to the level of land development within each TAZ and inversely related to the distance (miles of travel) between the TAZs. Distance is expressed as miles of travel.

Mode Choice

Mode choice predicts how a trip will be taken. Will it be by foot, bike, automobile, mass transit, a ferry or some other means?

Characteristics of the trip maker (income, gender, etc.), trip purpose (shop, work, etc.) and the mode (cost, time, etc.) all affect the mode choice decision process.

Trip Assignment

After applying vehicle occupancy rates and balancing the production and attraction trip matrix, the resulting “origin/destination” matrix is assigned to the network.

Model Output

Results of the “4-step process” are reports identifying traffic impacts on the overall system and each street segment measured by the relationship of the facility capacity to facility volume. Typical model outputs include:

- vehicle miles of travel (VMT)
- vehicle hours of travel (VHT)
- number of trips
- trip length
- hours of delay
- congested speeds
- congested travel times
- directional and non-directional daily and peak hour volumes, bandwidths
- volume/capacity ratios (V/C)